

Laboratory 4: Electric Circuits – Prelab

1 Current and moving charges

A typical current in an electronic device might be 5.0×10^{-3} A. Determine the number of electrons that pass through the device in one minute.

2 Electric potential and energy

In a particular electronic circuit there is a device for the difference in electric potential from one end of the device to the other is 5.0 V. Determine the energy required to move one electron from one end of this device to the other.

Laboratory 4: Electric Circuits – Activity

1 Currents in Simple Circuits

The simplest electric circuits consist of a single device, such as a bulb or a resistor, connected to a battery or power supply. The operation of such circuits can be understood in terms of currents through devices and voltages across these. This lab explores the relationship between these in the context of simple circuits.

- Follow the instructor’s description for connecting a light bulb and switch to a power supply (in series).
- Turn the voltage knob on the power supply to zero (counterclockwise as far as possible). Close the switch, turn the power supply on and gradually increase the voltage to about 3 V. Describe what the bulb does as the voltage increases.

- Such circuits are represented by a *circuit diagram* consisting of symbols that represent the devices and straight line sections that represent wires. Figure 1 illustrates some common circuit symbols. Circuit diagrams are usually drawn with the power supply battery vertically on the left and remaining devices vertically (as much as is possible) to the right. Connecting wires are straight except for corners which are at right angles. Draw a circuit diagram for the circuit of part 1 a).

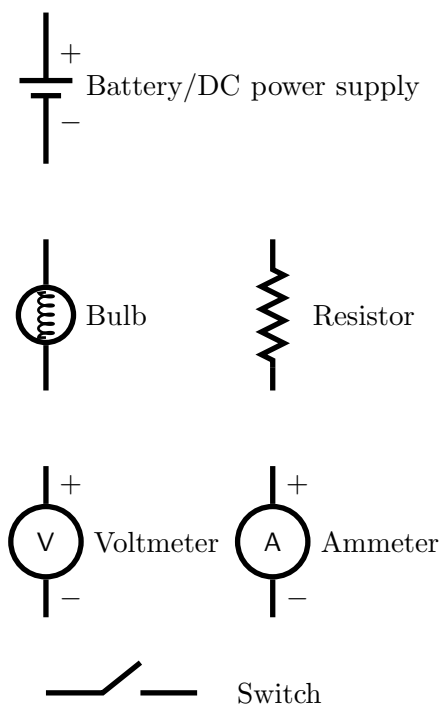

Figure 1: Circuit symbols

- d) Connect the circuit illustrated in Fig. 2. Close the switch and observe whether the bulb lights up. If it does not, explain why not.

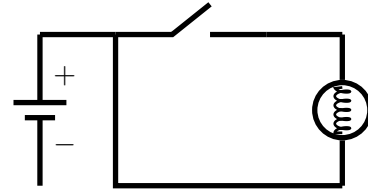

Figure 2: Trial circuit

In such circuits charged particles flow from one terminal of the battery through the circuit to the other terminal. A device like a light bulb only works when charges pass through it; the passing charges collide with the material in the bulb filament, heating it and causing it to glow. The greater the rate at which charges pass, the brighter the bulb will glow. The *current* at any point in the circuit is the rate at which charge flows past that point. Thus if charge ΔQ passes in time Δt then the current is

$$I = \frac{\Delta Q}{\Delta t}.$$

The bulb indicates the current indirectly via its brightness.

We consider the steady state of such circuits, meaning that there is no change in the circuit's behavior with time. Thus at any location, charge cannot accumulate or disappear as time passes.

- e) Consider the circuit of part 1 a). Predict whether the current before the bulb (i.e. between the positive terminal of the power supply and the bulb) differs from that after the bulb.

Reconnect the circuit of part 1 a). Connect an ammeter between the bulb and the positive terminal of the power supply (see page 10 for connection instructions) and measure the current. Repeat this, connecting the ammeter between the bulb and the negative terminal of the power supply, ensuring that the power supply settings are the same. Record the measured currents and compare these results with your

predictions. Would you say that “current is consumed by the bulb?” Would you say the “charge is consumed by the bulb?”

Use your results to determine the number of electrons that flow through the bulb per second.

Background information: The electrons in the connecting wires flow at a typical speed called the drift velocity, v_d . Suppose that the wire has cross sectional area A and consider the flow over a period of time Δt . Then all electrons within a region of volume $Av_d\Delta t$ will flow past a given point. If the density of electrons per unit volume is n_e , the the number of electrons that flow past this point in time Δt is $n_eAv_d\Delta t$. Thus the total charge flowing past this point is $\Delta q = en_eAv_d\Delta t$. Then the current flowing is $I = \Delta q/\Delta t$ and this gives

$$I = en_eAv_d.$$

- f) The conducting wires are made of copper for which $n_e = 8.5 \times 10^{28}$ per m^3 . Determine an approximate cross sectional area of one of the wires and use this to calculate the drift velocity for the current that you measured in the wire.

- c) Connect the circuit illustrated in Fig. 3. Vary the power supply voltage in steps of about 1 V, recording the voltage across the resistor and the current through the resistor for each setting. Plot the voltage across the resistor (in Volts) versus the current through the resistor (in Amps). This plot should be done accurately using either Excel or accurately scaled graph paper. What type of graph does this yield?

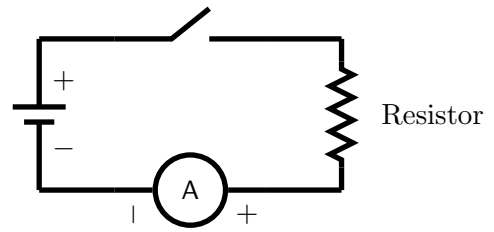

Figure 3: Resistor circuit

For many devices, the potential difference across the device is proportional to the current that flows through it. Specifically

$$\Delta V = RI$$

where ΔV is the potential across the device, I is the current that flows through it and R is the resistance of the device.

- d) Determine the resistance of your resistor **using your plot of voltage versus current** and note this.

3 Series Circuits

Devices can be combined within a single circuit. One of the simplest combinations involves devices connected so that the current flows through all devices in succession. The following exercises and demonstrations consider circuits which contain bulbs connected in such series arrangements. Your predictions will all be qualitative and rely on the fact that, for identical bulbs, the brightness increases when the current through the bulb increases. Assume that all the bulbs involved in the following circuits are identical.

- a) Two bulbs connected as illustrated in Fig 4 are said to be **in series**. Predict how the brightness of bulb A compares (brighter, dimmer, the same) to that of bulb B when the switch is closed. Explain your answer.

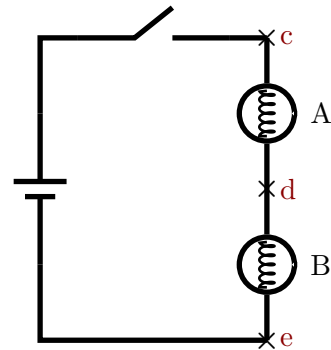

Figure 4: Bulbs in series

- b) Build the circuit and check whether your prediction was correct. If it was not, modify (in the space below) the explanation that justified your prediction.

With the switch closed measure the currents at points c, d and e. Compare the results. Does the current split in this type of circuit?

- c) Consider the energy supplied to move one Coulomb of charge from one terminal of the power supply to another. Predict how this energy will be divided amongst the bulbs. Will it be divided equally or not? What does this imply about the voltage across bulb A in comparison to bulb B and in comparison to that provided by the

power supply?

With the switch closed measure the voltages across bulb A, bulb B and the power supply. Do your results agree with your predictions? Does voltage split in this type of circuit?

- d) Suppose that bulb B was removed from the circuit and replaced by a piece of wire. Predict how the brightness of bulb A in the circuit without B compares to that of bulb A with bulb B present (as illustrated in part 3a)). Explain your prediction.

You can check your prediction by the following simple modification of the circuit of part 3a). Replace bulb B by a piece of wire connecting d and e. Was your prediction correct? If it was not, modify (in the space below) the explanation that justified your prediction.

Equipment Set Up: Ammeter and Voltmeter

A variety of meters are available for reading currents (ammeter) and electric potential differences (voltmeter). The precise methods of setting these up vary from one device to another but the way in which they are connected is always the same.

- a) **Voltmeter:** The voltmeter is always connected in parallel across the device for which the potential difference is to be measured. Figure 5 illustrates an example where the voltmeter measures the potential difference across the bulb.

The voltmeter reading is equivalent to the electrostatic potential at the V terminal minus that at the COM terminal.

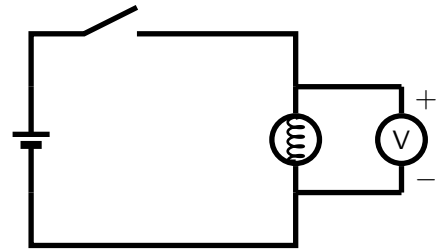

Figure 5: Voltmeter connection

- b) **Ammeter:** The ammeter is always connected in series with the components through which it measures current. Figure 5 illustrates an where the ammeter measures the current in the portion of the circuit prior to the bulb.

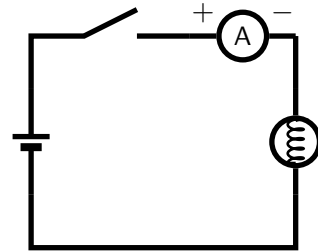

Figure 6: Ammeter connection