

## Phys 112: Supplementary Exercises

### Electrostatics

#### 1 Charged spheres

Various identical metal spheres are separated and charged. The excess charges on each sphere, whose charges have the same *magnitude*, are illustrated. The spheres are supported by insulating stands and are brought into contact and then later are separated. Determine the charge on each sphere after they have been in contact. Briefly explain your answers.

a) Before contact:

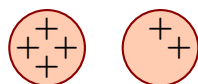

b) Before contact:

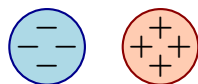

c) Before contact:

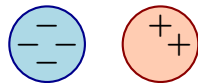

#### 2 Pairs of objects

Pairs of various objects that may or may not be charged are placed near each other and the observed interactions are as illustrated. What interaction would occur if C were placed near to B? Explain your answer.

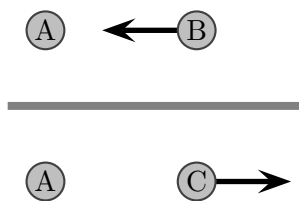

### 3 Interacting objects

Various objects, A, B, C and D, that may or may not be charged are placed near each other and the interactions are observed. It is observed that object A attracts object B, object A attracts object C and objects B and C do not interact. Object A repels object D.

- Can one determine the types of charge of B and C with certainty? If so what are they?
- Can one determine the types of charge of A and D with certainty? If so what are they?
- Suppose that D is placed near to B. Explain how it will interact with B.

### 4 Sphere, rod and wire

A metal sphere is initially uncharged. A positively charged rod is held near to but not touching the sphere. At this time a wire is briefly connected from the ground to the side of the sphere opposite to the rod and is then removed, while the rod is in place. Subsequently the rod is then removed. After all of this a small negatively charged ball is held near to the sphere. Will the sphere exert a force on the ball? If so is it repulsive or attractive? Explain your answer. *Hint: ground can supply and absorb charged particles.*

### 5 Number of electrons

Copper consists of atoms that each have 29 electrons and mass  $1.06 \times 10^{-25}$  kg. Copper has a density of  $8.69 \text{ kg/m}^3$ .

- Determine the number of electrons in a cube of pure copper with sides of length 2.0 cm. Assume that the copper is electrically neutral.
- Suppose that electrons are removed from the copper so that it has a net charge of  $5.0 \times 10^{-9} \text{ C}$  (this is a typical number for capacitors in electronic circuits). Determine the number of electrons that have been removed.
- What fraction of the total number of electrons in the copper were removed to give it charge  $5.0 \times 10^{-9} \text{ C}$ ?

### 6 Electric forces and charge magnitude

Two charged particles, A on the left and B on the right, are held at fixed locations. The charges on the particle can be adjusted while their locations stay fixed.



- Suppose that the charge of B is tripled. By how many times does this increase the force that A exerts on B? Explain your answer.
- Suppose that the charge of B is tripled. By how many times does this increase the force that B exerts on A? Explain your answer.
- Suppose that the charge of A is tripled and the charge of B is also tripled. By how many times does this increase the force that A exerts on B? Explain your answer.
- Suppose that the charge of A is tripled and the charge of B is also tripled. By how many times does this increase the force that B exerts on A? Explain your answer.

### 7 Electric forces and pairs of charges

Two charged particles, A and B, are held fixed. Let  $F_{A \text{ on } B}$  be the magnitude of the force exerted by A on B and  $F_{B \text{ on } A}$  be the magnitude of the force exerted by B on A. Which of the following is true? Explain your answer.

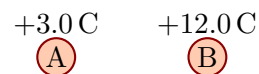

- i)  $F_{B \text{ on } A} = \frac{1}{4} F_{A \text{ on } B}$
- ii)  $F_{B \text{ on } A} = F_{A \text{ on } B}$
- iii)  $F_{B \text{ on } A} = 3F_{A \text{ on } B}$
- iv)  $F_{B \text{ on } A} = 4F_{A \text{ on } B}$
- v)  $F_{B \text{ on } A} = 12F_{A \text{ on } B}$

### 8 Electric forces and charges in a line

Three charged particles, A on the left, B in the center and C on the right, are held at fixed locations in a line. The distance between A and B is the same as between B and C and this is 2000 m. Rank the magnitudes of the net forces on each charge from smallest to largest. Explain your answer.

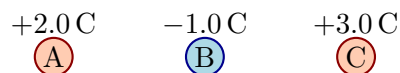

### 9 Two dimensional charge arrangements

Three charged particles are held fixed as illustrated; the grid units are each 0.010 m. Determine the magnitude and direction of the net force on charge C.

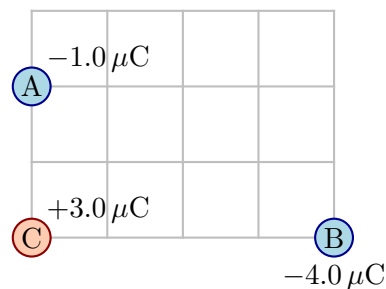

### 10 Two dimensional charge arrangements

Four charged particles are held fixed as illustrated; the grid units are each 0.010 m.

- a) Determine the net force on charge B.
- b) Determine the net force on charge D.
- c) Determine the net force on charge C.

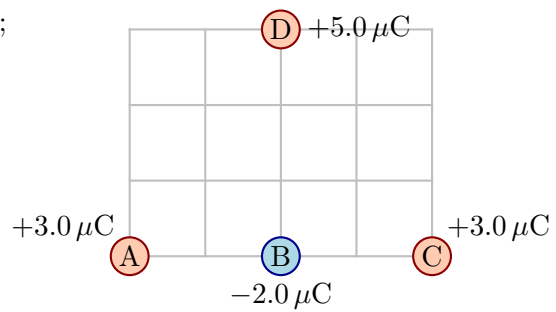

### 11 Air breakdown field

Air breaks down (produces sparks and lightning) when the electric field reaches about  $3.0 \times 10^6 \text{ N/C}$ . A metal sphere with radius  $0.20 \text{ m}$  carries a charge uniformly distributed on its surface and in this case, outside the sphere, the electric field is exactly the same as that produced if all the charge were concentrated at the center. Determine the charge that the sphere must carry so that the air at its surface breaks down.

### 12 Electric field and forces at various locations

Hidden source charges produce the illustrated electric field.

- a) Determine the force exerted on a proton that is placed at A. Determine the acceleration of a proton at this point.  $8 \times 10^3 \text{ N/C}$   $4 \times 10^3 \text{ N/C}$
- b) Determine the force exerted on an electron that is placed at B. Determine the acceleration of an electron at this point.
- c) Determine the force exerted on an electron that is placed at C. Determine the acceleration of an electron at this point.
- 

### 13 Electric field at various locations

A charged particle is held fixed as illustrated; the grid units are each  $0.010 \text{ m}$ . Determine the electric field vector at each point A, B, C and D. Draw the vectors on the diagram (or on a copy of the diagram).

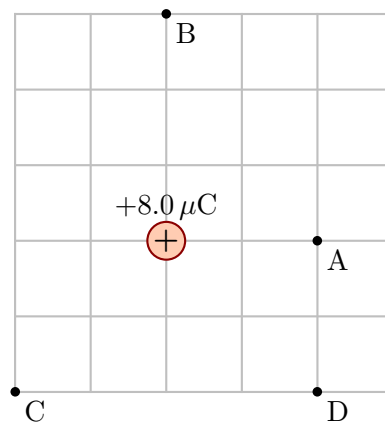

### 14 Electric fields and forces

Two charged particles (sources) are held at fixed locations. A probe charge is placed at location A. Which of the following is true? Explain your answer.

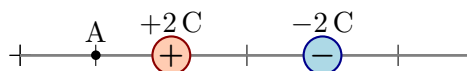

- i) The electric field at A is zero because the total charge is zero.
- ii) The electric field at A points in one direction for a positive probe and the opposite for a negative probe; the force on the probe points in the same direction regardless of the probe.
- iii) The electric field at A points in one direction for a positive probe and the opposite for a negative probe; the force on the probe points one direction for a positive probe and the opposite for a negative probe.
- iv) The electric field at A points in the same direction regardless of the probe charge; the force on the probe points in the same direction regardless of the probe charge.
- v) The electric field at A points in the same direction regardless of the probe charge; the force on the probe points in different directions depending the probe charge.

### 15 Electric fields produced by multiple charged particles and forces.

Two charged particles are held at fixed locations. Various probe charges are placed at the midpoint.

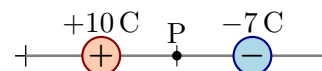

- a) Does the direction and magnitude of the electric field produced by the two illustrated particles change when a positive probe at P is replaced by a negative probe at P?
- b) Do the direction and magnitude of the force exerted on a probe placed at P change when a positive probe is replaced by a negative probe?

Explain your answers.

### 16 Electric field ranking

Three isolated pairs of charges are separated by the same distance in the three situations illustrated below. Rank the magnitudes of the electric fields at the midpoints (labeled P) from smallest to largest. Explain your answers.

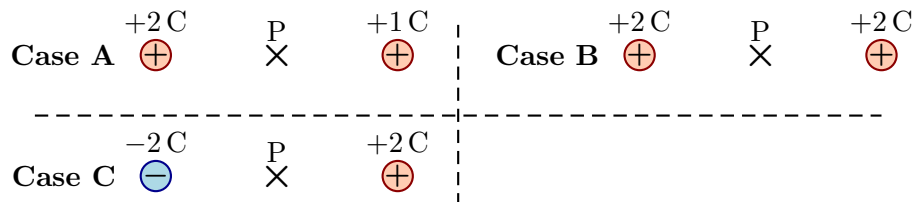

**17 Electric fields at different locations**

Two charged particles are held at fixed locations. Is the magnitude of the electric field produced by these charges at point A larger than, smaller than or the same as at point B? Explain your answer.



**18 Net electric field**

Two hidden arrangements of charged particles each produce an electric field, i.e. one electric field vector at each point. These are illustrated at two points. The net electric field at any point is the sum of the two field vectors at each point. Use vector components to determine the net electric field at point A and the net electric field at point B.

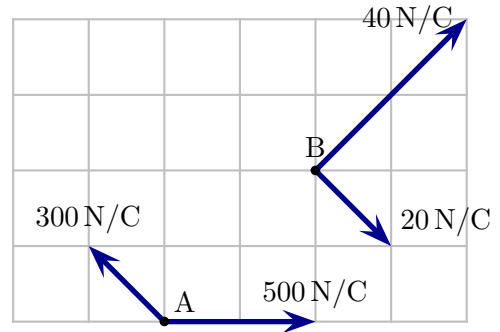

**19 Electric field produced by two point charges**

Two charged particles are held fixed as illustrated; the grid units are each 0.010 m. The aim of this exercise will be to determine the field at point P.

- Indicate the directions of the electric fields produced by each source charge at point P.
- Determine the magnitude of the electric field produced by each source charge at point P.
- Using vector components add the two electric fields.

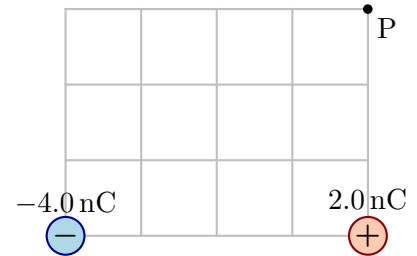

## 20 Electric fields in two dimensions

Three arrangements of two charged particles are as illustrated. Rank the electric fields in order of increasing magnitude, indicating equal cases where applicable. Explain your answer.

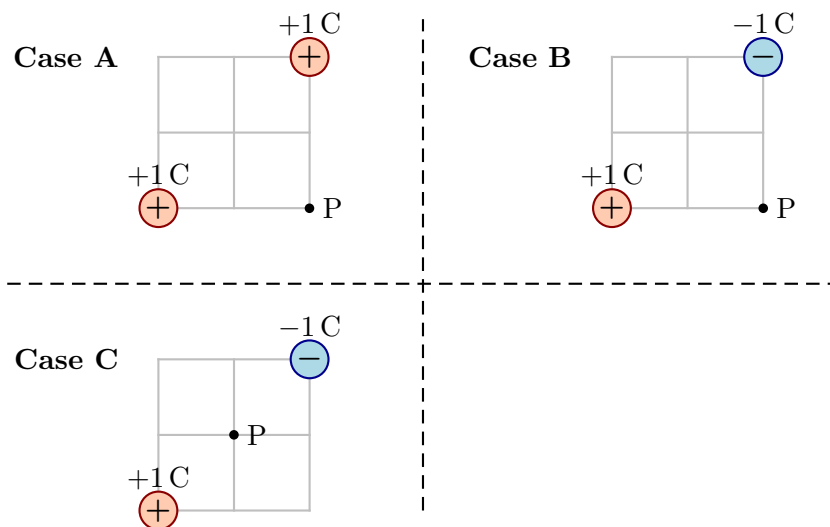

## 21 Electric field produced by two charges in two dimensions

In each of the following, fixed charges are held fixed as illustrated. The grid units are each 0.020 m. Determine the electric field at point P in each case.

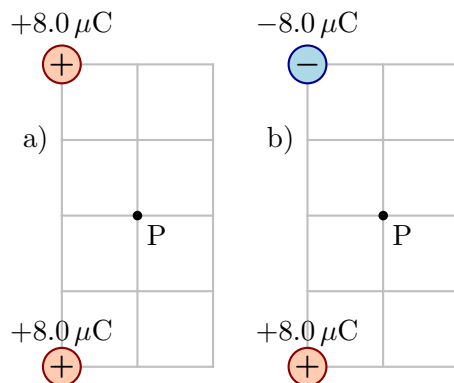



## 22 Electric field produced by two charges in two dimensions

In each of the following fixed charges are held fixed as illustrated. The grid units are each 0.020 m. Determine the electric field at point P in each case.

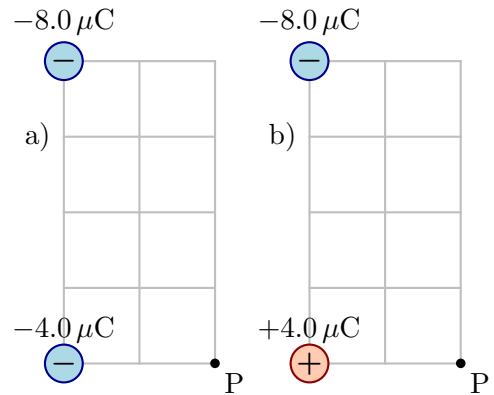

## 23 Electric field produced by multiple charges in two dimensions

Three charged particles are held fixed as illustrated; the grid units are each 0.020 m.

- Determine the electric field at point P.
- A particle with charge  $+3.0 \mu\text{C}$  is placed at P. Determine the force exerted on this particle by the other charged particles.
- A particle with charge  $-3.0 \mu\text{C}$  is placed at P. Determine the force exerted on this particle by the other charged particles.

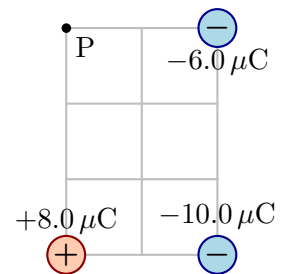

## 24 Electric field produced by two point charges

Two charged particles are held fixed as illustrated; the grid units are each 0.010 m. The aim of this exercise will be to determine the field at point P.

- Indicate the directions of the electric fields produced by each source charge at point P.
- Determine the magnitude of the electric field produced by each source charge at point P.
- Using vector components add the two electric fields. Sketch the net electric field vector and determine its magnitude.

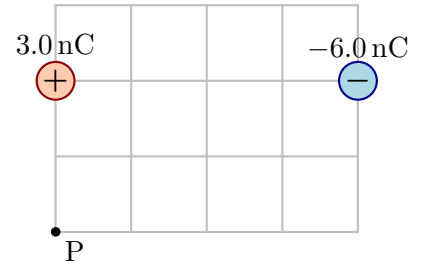

## 25 Motion of a charge near a point source

A point source charge is held fixed as illustrated. Various probe charges are released from rest at point X.

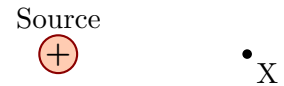

- a) Suppose that a proton is released from rest at point P. Which of the following is subsequently true? Explain your choice.
- i) The proton moves right with constant speed.
  - ii) The proton moves right with constantly increasing speed.
  - iii) The proton moves right with constantly decreasing speed.
- b) Suppose that an electron is released from rest at point P. Which of the following is subsequently true? Explain your choice.
- i) The electron moves left with constant speed.
  - ii) The electron moves left with constantly increasing speed.
  - iii) The electron moves left with constantly decreasing speed.

## 26 Particle moving in a uniform electric field

Two closely spaced plates are uniformly charged; that on the left is positive and that on the right is negative. The distance between the plates is 0.0080 m. The electric field between the plates points to the right. An electron is launched from the left plate with speed  $3.0 \times 10^6$  m/s and travels to the right plate. It stops just before reaching the right plate.

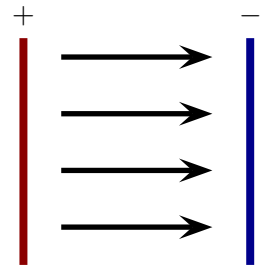

- a) Determine the acceleration of the electron.
- b) Determine the magnitude of the electric field.

## Electrostatic Potential

### 27 Motion in a potential

Hidden source charges produce an electric potential as illustrated. Other probe charges move between various locations as illustrated. Let  $v_1$  be the speed of the probe at point 1,  $v_2$  be the speed at point 2, etc.

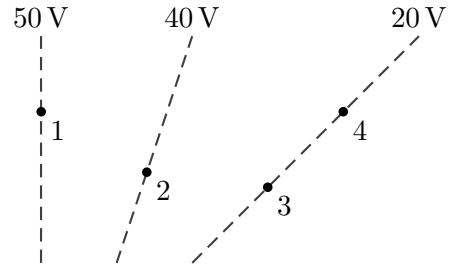

- A proton moves from point 1 to point 2. Is  $v_2$  the same as, larger than or smaller than  $v_1$ ?
- An electron moves from point 1 to point 2. Is  $v_2$  the same as, larger than or smaller than  $v_1$ ?
- Two electrons are released from rest at points 3 and 4 in separate experiments. Both reach point 1. How do their speeds compare when they reach point 1?
- A proton is released from rest at point 1 and moves to point 4. Separately another proton is released from point 2 and it moves to point 3. Which proton moves faster when it reaches the 20 V line, or are their speeds the same at this stage?

### 28 Accelerating electrons

Electrons can be made to accelerate by creating an electrostatic potential difference across a region of space.

- Suppose that an electron is initially at rest and moves through a region where the potential difference is 100 V. Determine the speed of the electron at the end of this region.
- Through what potential difference must an electron be accelerated so that it reaches a speed of  $1.5 \times 10^7$  m/s if it was initially at rest?

### 29 Electrostatic potential between plates

Two parallel plates are charged. The electrostatic potential is such that it is constant along lines that are parallel to the plates. Several of these are as illustrated. Positively charged particles are moved between the two points.

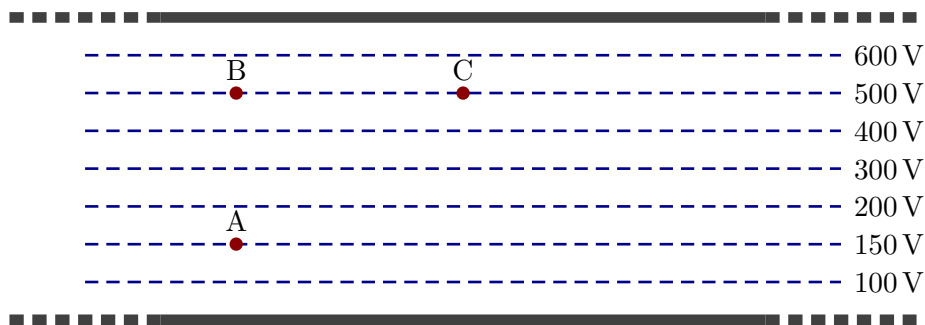

- A charge is released at A with an initial velocity in the vertical direction and moves to B in a straight line. In a separate experiment the same charge is released at A with velocity of the same magnitude, but angled away from the vertical. It moves in a curved path, arriving at C. How does the change in electrostatic potential energy in the A  $\rightarrow$  B case compare to that of the A  $\rightarrow$  C case? How does the final speed in the A  $\rightarrow$  B case compare to that of the A  $\rightarrow$  C case?
- The particle is made to move in two paths from B to C at a constant speed (an external force will be required to do this). One path is a straight line from B to C and the other a semicircular path within the plates from B to C. Compare the changes in total energy and the net work done by the external force in the two cases. Do your answers depend on the path taken? Would they be valid for any path taken?

### 30 Electric potential at various locations

A charged particle is held fixed as illustrated; the grid units are each 0.010 m.

- Determine the electric potential at each point A, B, C and D.
- Determine and describe all possible locations at which the electric potential is 900 V. Use the diagram (or a copy of the diagram) to illustrate these locations.

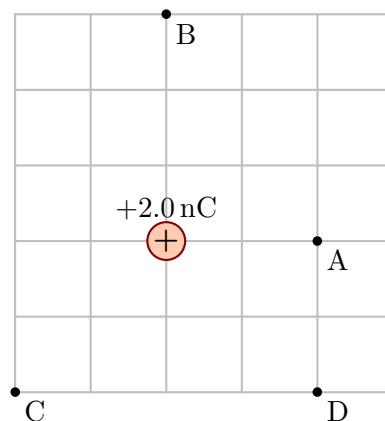

### 31 Motion around a point charge

A negatively charged particle is held fixed as illustrated. A proton moves in the illustrated circular trajectory. Explain your answers for the following.

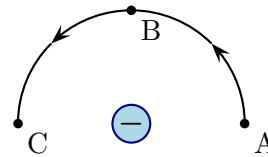

- Does the electric potential energy of the proton increase, decrease or stay the same as it moves from A to B?
- Is the speed of the proton at B larger, smaller or the same as at A?
- Does the electric potential energy of the proton increase, decrease or stay the same as it moves from B to C?
- Is the speed of the proton at C larger, smaller or the same as at B?
- Is the speed of the proton at C larger, smaller or the same as at A?

### 32 Proton fleeing a positive source charge

A point particle has charge  $+20.0 \text{ nC}$  and is held fixed. A proton is released at a distance of  $0.050 \text{ m}$  from the charge.

- Determine the speed with which the proton travels when it is  $0.10 \text{ m}$  from the charge.
- Determine the speed with which the proton travels when it is  $10.0 \text{ m}$  from the charge.
- Determine the speed with which the proton travels when it is  $100.0 \text{ m}$  from the charge. Does its speed change much as it continues beyond this point?

### 33 Alpha particle and a gold nucleus

An alpha particle consists of two protons and two neutrons. Suppose that an alpha particle is directed toward a nucleus of a gold atom (the nucleus contains neutrons and 79 protons). Assume that the alpha particle is fired with speed  $3.0 \times 10^6 \text{ m/s}$ . This speed is sufficient that the force exerted by the electrons can be ignored to some extent; assume that it is negligible.

- If the alpha particle is fired from infinitely far away, determine the closest that it approaches the center of the nucleus (ignore the electrons in the gold atom).
- Clearly the alpha particle cannot be fired from infinitely far away. Assume that it is fired from  $2.0 \text{ m}$  with the same speed toward the nucleus. Determine the closest that it approaches the center of the nucleus. Does this differ much from the result if it were fired from infinitely far away?

### 34 Electric potential for two charges

Various arrangements of two charged particles are as illustrated. In each case rank the potentials at the indicated points in order from smallest to largest. Explain your answer.

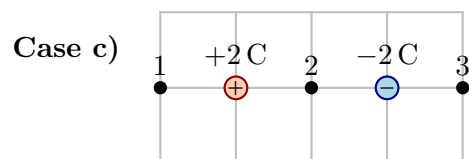
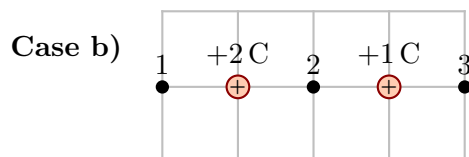
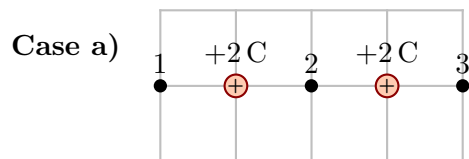

### 35 Potential from multiple point source charges

Various source charges are held at rest as illustrated. The grid units are 0.010 m. Determine the electric potential at point P.

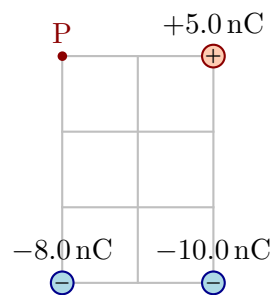

### 36 Escape speed of a particle

A 0.0050 kg sphere with charge  $-0.0080\text{ C}$  is held at rest at the point labeled P in the vicinity of various fixed charges as illustrated. The grid units are 0.010 m. The sphere is released. Determine the speed of the sphere when it is infinitely far from the illustrated charges.

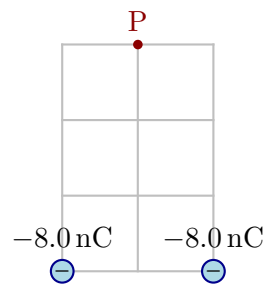

### 37 Particles in a potential

Hidden source charges produce the illustrated potential. Various probe charges are, in separate experiments, released from rest at the indicated locations.

- A positive charge is released from A. In which direction and how far will it move?
- A positive charge is released from B. In which direction and how far will it move?
- A negative charge is released from A. In which direction and how far will it move?
- A negative charge is released from B. In which direction and how far will it move?

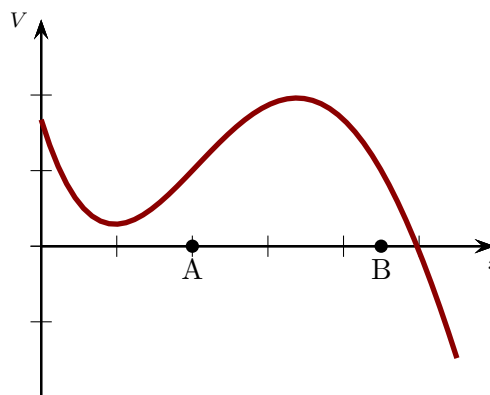

### 38 Particles in a potential

Various metal plates that are perpendicular to the  $x$  axis produce the illustrated electric potential. The horizontal axis units are meters and the vertical axis units are Volts.

- A sphere with mass  $0.020\text{ kg}$  and charge  $-8.0 \times 10^{-2}\text{ C}$  is released from rest at  $x = 0\text{ m}$ . Determine its speed when it is at  $x = 2.0\text{ m}$  and again at  $x = 5.0\text{ m}$ .
- A sphere with mass  $0.40\text{ kg}$  and charge  $+7.5 \times 10^{-2}\text{ C}$ , moves left at  $x = 5\text{ m}$  with speed  $5.0\text{ m/s}$ . Determine its subsequent minimum speed.

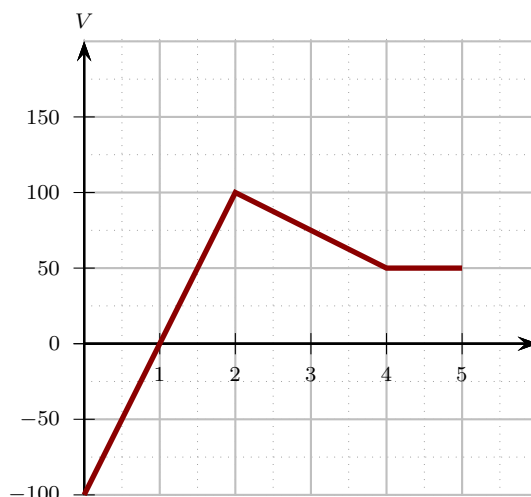



### 39 Equipotentials and fields

Each of the illustrations shows a set of equipotentials produced by hidden charges. Describe whether the magnitude of the electric field at A is large than, smaller than or the same size as that at B. Explain your answers.

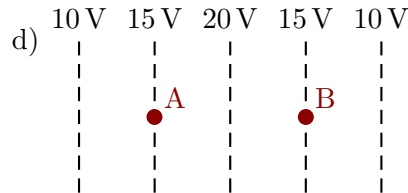
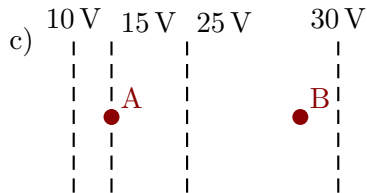
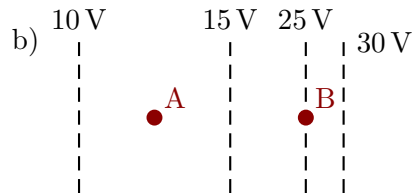
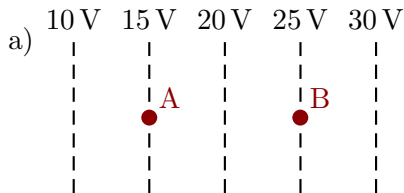

### 40 Potentials and motion

Various metal plates that are perpendicular to the  $x$  axis produce the illustrated electric potential. The horizontal axis units are meters and the vertical axis units are Volts. In separate experiments, electrons are released from rest at the indicated locations, A, B, C, and D.

- At each location, describe whether the electron moves and, if so, in what direction.
- Rank the magnitudes of the accelerations of the electrons that are placed at the four locations.

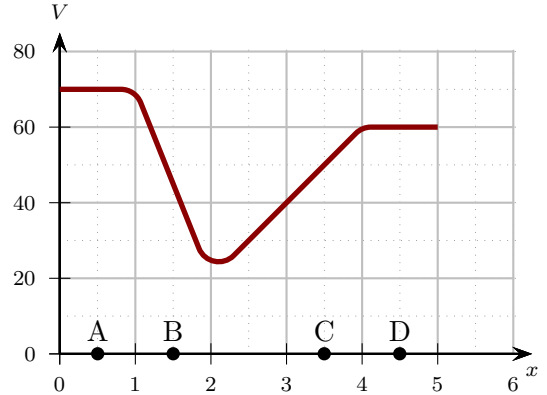

#### 41 Potentials and fields

Various metal plates that are perpendicular to the  $x$  axis produce the illustrated electric potential. The horizontal axis units are meters and the vertical axis units are Volts. Determine the electric field at points A,B,C and D.

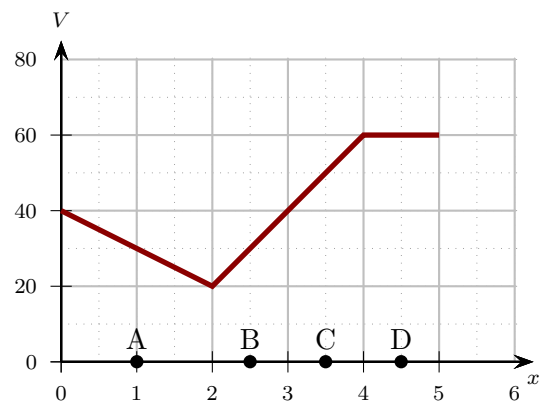

## Currents and Circuits

### 42 Current and particle flow

A battery is connected to a bulb as illustrated. Explain your answers to the following questions.

- Suppose that the current consists of positively charged particles that flow around the circuit. Consider one such particle. Will it flow from the 3 V terminal to the 0 V or the other way round? Based on your answer, is current direction clockwise or counterclockwise around the circuit?
- Suppose that the current consists of negatively charged particles that flow around the circuit. Consider one such particle. Will it flow from the 3 V terminal to the 0 V or the other way round? Based on your answer, is current direction clockwise or counterclockwise around the circuit?
- Does the direction of the current around this circuit depend on whether the particles that move are positive or negative?

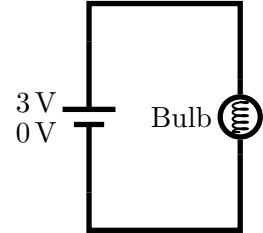

### 43 Currents at junctions

A battery and bulbs are connected in the illustrated circuit. The current in C is the same as in D. Suppose that the current in A is 6 A and the current through the battery is 10 A. Determine the currents through the other bulbs.

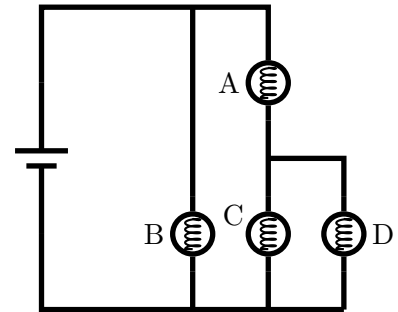

#### 44 Energy and currents

A battery and bulb are connected in the illustrated circuit. A steady current of  $2.0\text{ A}$  flows through the bulb.

- Assume that positive charge moves from point A to point B. Determine the charge that passes point B in  $5.0\text{ s}$ . Determine the change in electrostatic potential energy of this charge as it moves from point A to point B. Does the charge gain or lose electrostatic energy?
- Using the same data as above, assume that negative charge moves from point B to point A. Determine the change in electrostatic potential energy of this charge as it moves from point B to point A. Does the charge gain or lose electrostatic energy?
- Suppose that the battery can provide  $9.6\text{ kJ}$  of energy. Determine the amount of time for which the battery could operate in this circuit.

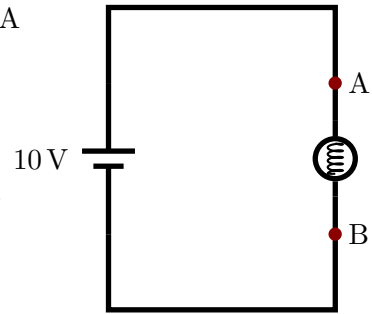

#### 45 Currents in bulbs

Various bulbs are connected to a battery in the illustrated circuit.

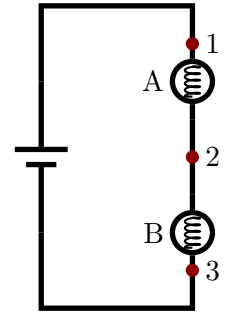

- Suppose that bulbs A and B are identical. Rank the currents at points 1, 2, and 3, in order of decreasing current, indicating equality whenever it occurs. Explain your answer.
- Suppose that bulb A has a greater resistance than bulb B. Rank the currents at points 1, 2, and 3, in order of decreasing current, indicating equality whenever it occurs. Explain your answer.
- Suppose that bulb A has a smaller resistance than bulb B. Rank the currents at points 1, 2, and 3, in order of decreasing current, indicating equality whenever it occurs. Explain your answer.

#### 46 Air conditioner power

A window unit air conditioner uses power 1400 W and has a thermostat that turns it on and off. During the summer it runs for 9.0 hr every day. The air conditioner is connected to the 120 V mains outlet.

- Determine the total energy consumed by the air conditioner in a day.
- Determine the electrical current that flows into the air conditioner as it runs.

#### 47 Toaster resistance

A toaster provides power 1200 W when it is connected to a 120 V mains outlet.

- Determine the resistance of the toaster.
- Suppose that the toaster is connected to a 240 V outlet. Determine the power that it provides, assuming that its resistance stays constant.

#### 48 Resistors in series

Determine the currents through, voltages across and the power dissipated by each resistor in the illustrated circuit.

- Determine the current in the circuit.
- Determine the potential difference across each resistor.
- Determine the power delivered to each resistor.

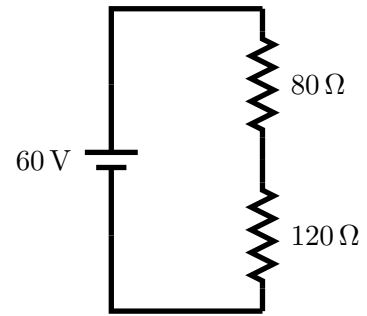

#### 49 Resistors in series

Two resistors are connected as illustrated.

- Determine the current in the circuit.
- Determine the potential difference across each resistor.
- Determine the power delivered to each resistor.

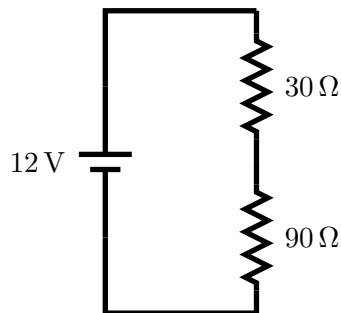

#### 50 Resistors in series

Consider the resistors in the illustrated circuits. Let  $P_A$  be the power delivered to A, etc. Which of the following is true? Explain your answer.

- $P_A = P_B = \frac{1}{4} P_C$
- $P_A = P_B = \frac{1}{2} P_C$
- $P_A = P_B = P_C$
- $P_A = P_B = 2P_C$
- $P_A = P_B = 4P_C$
- $P_A > P_B = P_C$

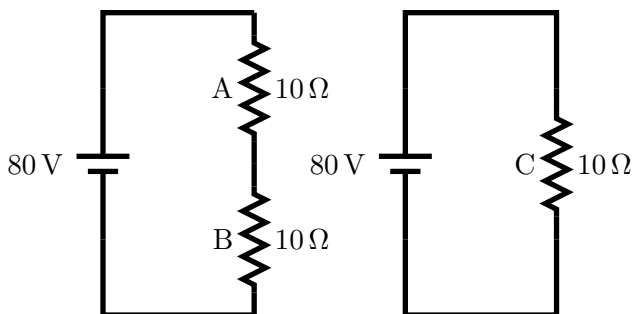

#### 51 Bulbs in series

A battery and bulbs are connected in the illustrated circuit. The resistance of A is three times the resistance of B.

- Determine the ratio of the currents through the bulbs,  $I_B/I_A$ .
- Determine the ratio of the potential differences across the bulbs,  $\Delta V_B/\Delta V_A$ .
- Determine the ratio of the powers dissipated by the bulbs,  $P_B/P_A$ .

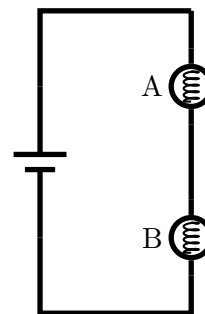

#### 52 Currents in bulbs

Various identical bulbs are connected to identical batteries in the illustrated circuits.

- Rank the bulbs A, B, and C in order of increasing brightness. Explain your answer.
- Rank the bulbs D, E, and F in order of increasing brightness. Explain your answer.

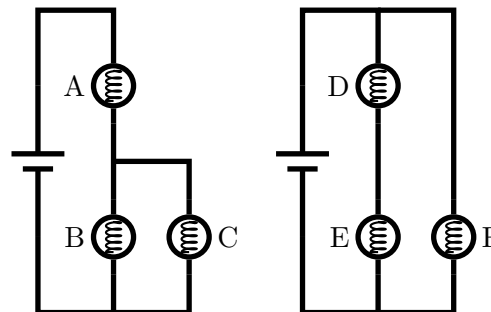

### 53 Currents in bulbs

A battery and identical bulbs are connected in the illustrated circuit. Rank the bulbs in order of increasing brightness.

- Rank the bulbs in order of increasing brightness. Explain your answer.
- Suppose that bulb C is replaced by a wire. Describe the effect of this change on the brightness of bulb A and B. Explain your answer.

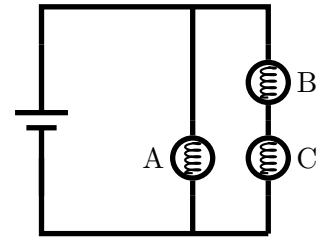



## Currents and Magnetic Fields

### 54 Field produced by a straight current

An infinitely long wire carries a 25 A current out of the page. Determine the magnetic field at each illustrated point. The solid grid blocks are each 1.0 cm wide.

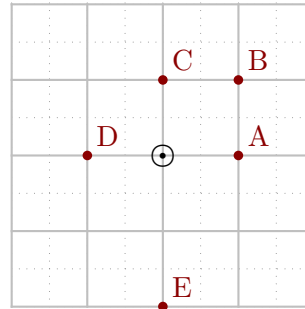

### 55 Field produced by pairs of straight currents

Two infinitely long wires are oriented as illustrated and each carry the same current. Rank the magnitudes of the net magnetic fields produced at the indicated points. Explain your answer.

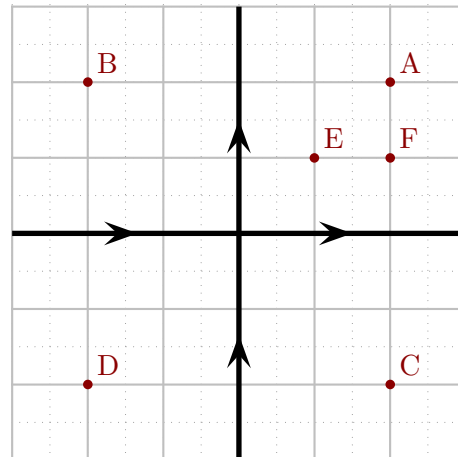

**56 Field produced by pairs of straight currents**

Two infinitely long wires are oriented as illustrated and carry currents as illustrated. Indicate the locations at which the net magnetic field is zero. Explain your answer.

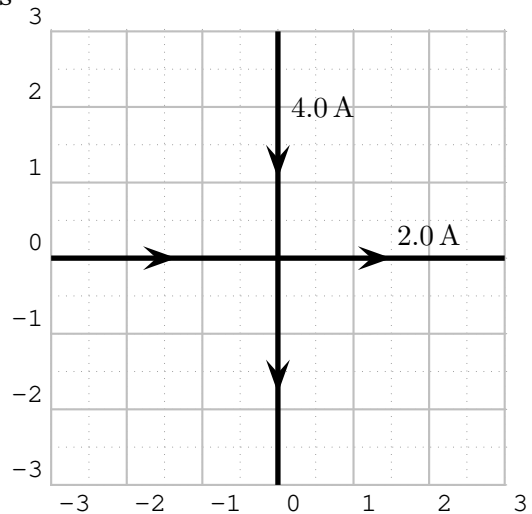

**57 Magnetic fields produced by parallel currents**

Infinitely long straight parallel wires carry the illustrated currents with identical currents. Consider the magnetic field at the points A, B (midway between the wires) and C. In each case rank the magnetic fields at the indicate locations in order of increasing magnitude. Indicate equality whenever it occurs.

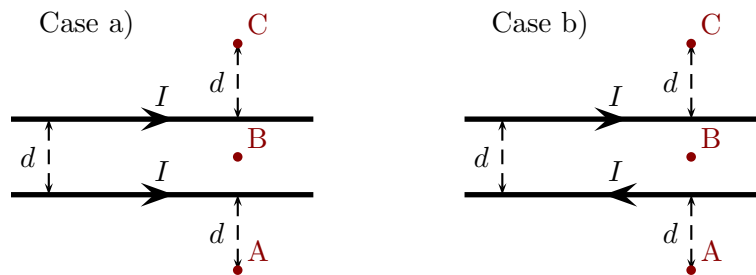

**58 Magnetic fields produced by parallel currents**

Two infinitely long straight parallel wires carry the illustrated currents with  $I_1 = 50 \text{ A}$  and  $I_2 = 30 \text{ A}$ . Suppose that  $d = 0.0020 \text{ m}$ . Determine the magnetic field at the points A, B (midway between the wires) and C.

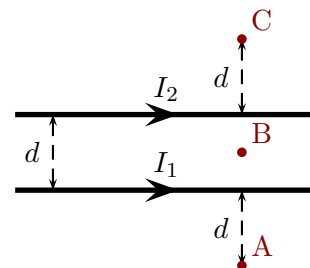

### 59 Field produced by a straight current in a uniform background field

An infinitely long wire is placed in the illustrated  $6.0 \times 10^{-3} \text{ T}$  uniform magnetic field (created by something else). The wire carries a  $300 \text{ A}$  current into the page. The solid grid blocks are each  $1.0 \text{ cm}$  wide. Determine the magnitude of the net magnetic field at each illustrated point.

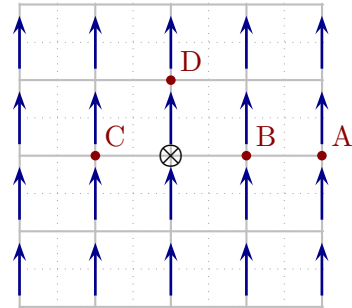

### 60 Magnetic fields produced by a circular loop

A circular loop carries a constant current.

- Suppose that the loop has radius  $0.50 \text{ cm}$ . Determine the current that it must carry in order to produce a  $25 \text{ T}$  magnetic field at the center of the loop.
- Suppose that the loop carries current  $40 \text{ A}$ . Determine the radius of the loop in order to produce a  $25 \text{ T}$  magnetic field at the center of the loop.

**61 Forces exerted by one current loop on a bar magnet.**

A current loop are situated above a bar magnet as illustrated. The loop is perpendicular to the plane of the page. Indicate the effective north and south ends of the loop and use these to describe the direction of the force that the loop exerts on the magnet. Indicate the direction of the force that the magnet exerts on the loop.

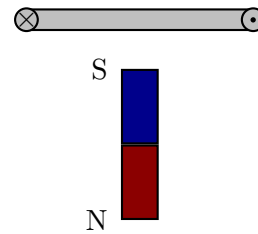

**62 Force exerted by one current loop on another.**

Two current loops are situated as illustrated; both are perpendicular to the plane of the page. Indicate the effective north and south ends of each loop and use these to describe the direction of the force that the upper loop exerts on the lower loop.

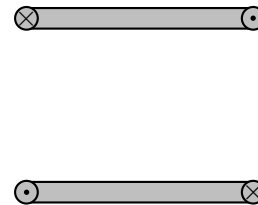

## Magnetic Forces

### 63 Force on a charged particle

Each of the following illustrates a charged particle moving in an external magnetic field. Indicate the direction of the force exerted by the magnetic field on the charged particle for each case. Explain your answer.

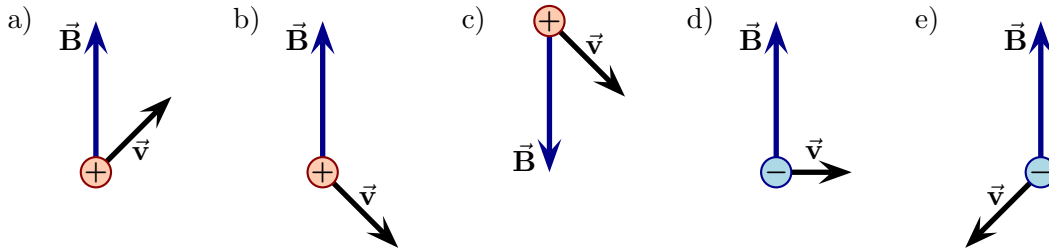

### 64 Force on a beam of particles

A beam of particles is fired at high speed and travels in a straight line. You view the beam traveling toward you. A magnet is held as illustrated and the beam is deflected as illustrated. What charge do the particles have? Explain your answer.

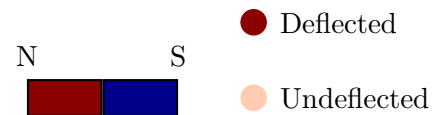

### 65 Force on a beam of electrons

A beam of electrons moves from left to right as illustrated. The electrons are placed in a uniform magnetic field.

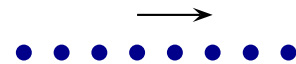

- If initially the electrons are to be deflected downwards, what is the direction of the magnetic field? Explain your answer.
- As the electrons continue to move in the uniform field, does the magnitude of the force on the electrons increase, decrease or stay the same? Explain your answer.
- As the electrons continue to move in the uniform field, does the speed of the electrons increase, decrease or stay the same? Explain your answer.

### 66 Charged particle in a field

A proton follows the illustrated trajectory in a magnetic field. What is the direction of the magnetic field? Explain your answer.

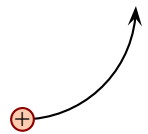

**67 Forces on wires**

Three wires each carry currents of identical magnitudes in the illustrated directions. The distance between adjacent wires are equal. Rank the wires in order of the magnitudes of the net magnetic force on each.

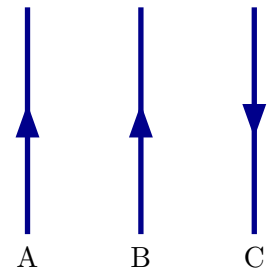

**68 Forces on wires**

Three wires each carry different currents as illustrated. The length of each wire is 0.75 m and the distance between adjacent wires is 0.020 m. Determine the net force on each wire.

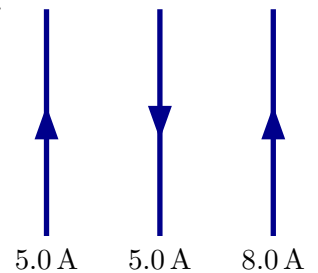

**69 Loop and wire**

A long straight wire carries a constant current as illustrated. Two loops carry current as illustrated. Describe the direction of the force exerted by the long straight wire on each loop.

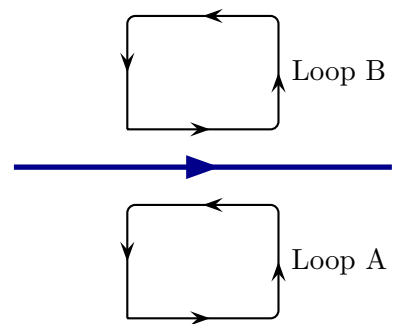

## 70 Current loop in a uniform magnetic field

A loop is placed in a uniform magnetic field and a current flows as illustrated. Initially the loop lies perpendicular to the magnetic field as illustrated.

- a) For the initial configuration, determine the direction of the force on each side of the loop. Use this to describe how the loop will move if it is released from rest in this position.

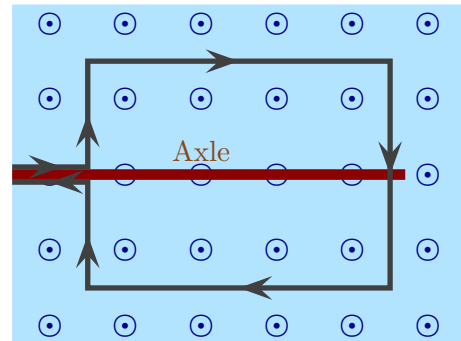

Suppose that later the loop lies in the plane of the magnetic field as illustrated.

- b) In this configuration, determine the direction of the force on each side of the loop. Use this to describe how the loop will move if it is released from rest in this position.

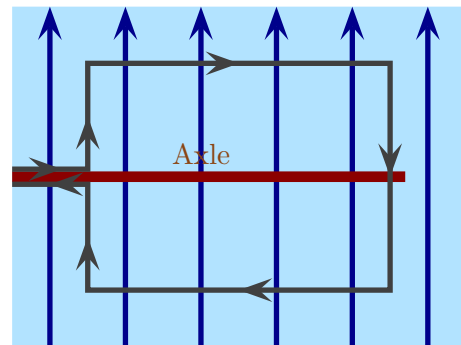

# Magnetic Induction

## 71 Motional EMF and current

In each of the following a loop lies partly in a uniform magnetic field and is dragged as illustrated. In each case, determine if the dragging produces any current and, if so, its direction. Explain your answers.

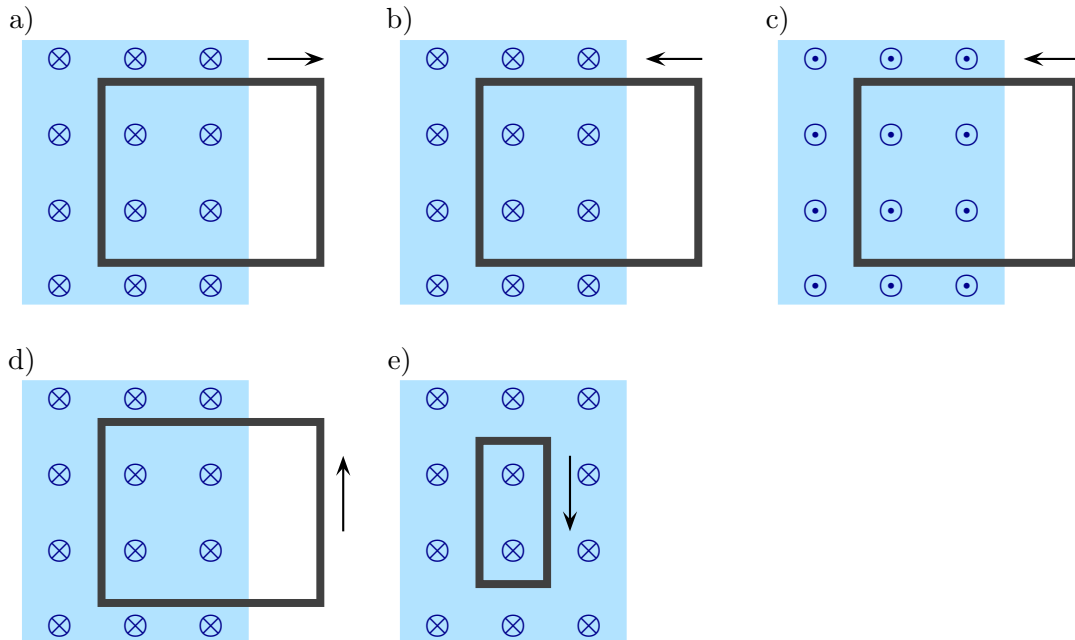



### 72 Loop moved near a permanent magnet

A circular loop is initially held at rest near to a bar magnet. The bar magnet lies along the axis of the loop. The loop is then pushed toward the magnet. In each of the following explain your answers.

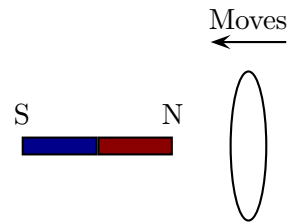

- While the loop is initially at rest, is there a current in the loop? If so, what is its direction (as viewed from the right edge of the diagram)?
- While the loop is initially at rest, does the magnet exert a force on the loop? If so, what is its direction?
- While the loop approaches the magnet, is there a current in the loop? If so, what is its direction (as viewed from the right edge of the diagram)?
- While the loop approaches the magnet, does the magnet exert a force on the loop? If so, what is its direction?
- The loop eventually passes “across” the magnet and moves left away from the magnet. During this period is there a current in the loop? If so, what is its direction (as viewed from the right edge of the diagram)? Does the magnet exert a force on the loop? If so, what is its direction?

### 73 Square loop around a solenoid

A square loop is placed around a solenoid, which can be approximated as infinitely long. The square loop and the solenoid are arranged so that their axes are along the same line. When viewed from the right, the current in the solenoid flows clockwise. In each of the following explain your answers.

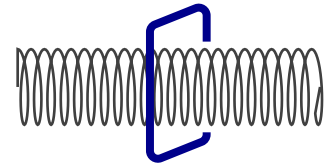

- Suppose that the current in the solenoid is constant. Is there a current in the loop? If so, what is its direction (as viewed from the right edge of the diagram)?
- Suppose that the current in the solenoid is increasing. Is there a current in the loop? If so, what is its direction (as viewed from the right edge of the diagram)?
- Suppose that the current in the solenoid is decreasing. Is there a current in the loop? If so, what is its direction (as viewed from the right edge of the diagram)?

### 74 Triangular loop in a magnetic field

The illustrated regions each have a uniform magnetic field with the same magnitude but opposite directions. A triangular loop is initially at the illustrated position. The loop can be dragged in various directions from this initial position. In each of the following explain your answers.

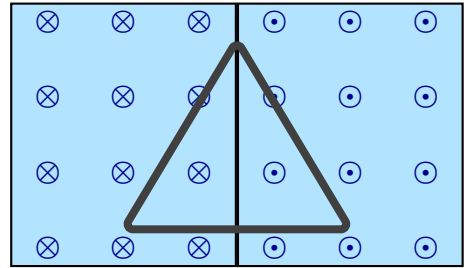

- Suppose that the loop is dragged vertically. Just after it starts to move, is there a current in the loop? If so, what is its direction?
- Suppose that the loop is dragged to the left. Just after it starts to move, is there a current in the loop? If so, what is its direction?
- Suppose that the loop is dragged to the right. Just after it starts to move, is there a current in the loop? If so, what is its direction?

### 75 Flux through a loop

A solenoid produces a flux through a loop of wire. A graph of the flux versus time is as illustrated. During which time intervals will there be a non-zero current in the loop? Explain your answer.

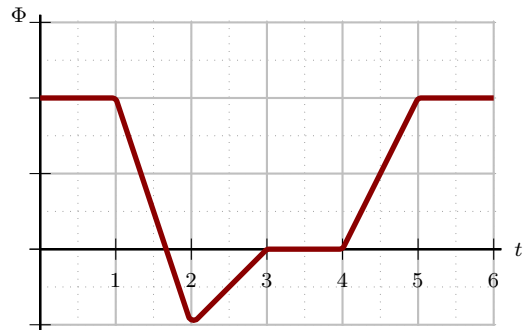

## 76 Changing magnetic fields and loops

In each of the following a loop lies in a uniform magnetic field which changes as time passes. Determine the direction of the induced current in the loop. Explain your answers.

- a) Field increases

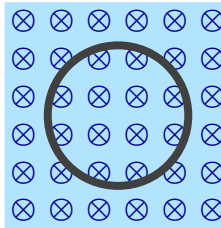

- b) Field decreases

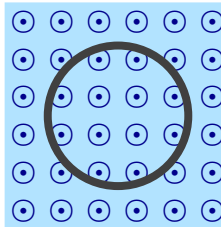

## 77 Induced currents

A conducting loop is in the vicinity of a long straight wire. The wire carries a current pointing in the illustrated direction. In each of the following situations describe whether there is a current in the loop and, if so, what its direction is. Explain your answers.

- The loop is fixed and the current in the straight wire steadily increases.
- The loop is fixed and the current in the straight wire steadily decreases.
- The current in the wire stays constant and the loop is pushed to the right.
- The current in the wire stays constant and the loop is pushed to the left.
- The current in the wire stays constant and the loop is pushed up (the page).

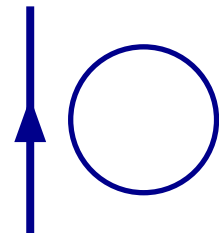

### 78 Loops partly in a field

A rectangular loop lies partly in a region of uniform magnetic field as illustrated. In the following, explain your answers.

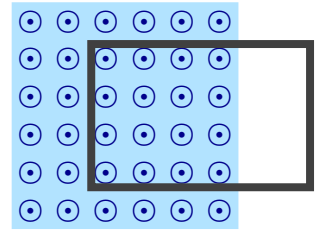

- The magnetic field increases as time passes. Determine the direction of the induced current in the loop. Determine the direction of the force exerted by the field on the loop.
- The magnetic field decreases as time passes. Determine the direction of the induced current in the loop. Determine the direction of the force exerted by the field on the loop.

### 79 Current around loops

Two circular loops, each with radius 0.040 m, are placed in a region of uniform magnetic field. Exactly half of loop B is in the magnetic field. The field strength increases from 0 T to  $2.0 \times 10^{-3}$  T over a period of 0.005 s.

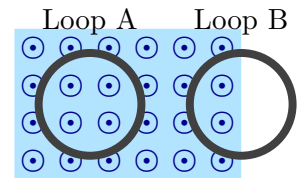

- The resistance of loop A is  $0.025 \Omega$ . Determine the EMF around the loop and the current through the loop.
- The resistance of loop B is  $0.005 \Omega$ . Determine the EMF around the loop and the current through the loop.

### 80 Inductive loading

Electronic circuits often contain loops of current that produce magnetic fields. Whenever the current in one loop changes, the resulting magnetic field changes and this can induce an EMF in an adjacent loop. As a simple model to illustrate such effects consider two closely spaced parallel circular loops, each with radius 3.0 cm. Suppose that one loop (loop A) contains a steady current of 0.50 A. Initially there is no current in the adjacent loop (loop B). Loop B contains a circuit device that will be destroyed if the voltage across it exceeds 10 V.

- Determine the magnetic field at the center of loop A.
- Assume that the magnetic field throughout loop B is the same as that at the center of loop A. Determine the flux through loop B.
- Suppose that the circuit is instantly turned off and the current in loop A drops to zero in  $0.5 \times 10^{-9}$  s. Determine the EMF induced in loop B while this happens. Will the device in loop B survive?

## Waves

### 81 Wavelength and frequency

Various waves on strings are as illustrated. The wave speeds are provided for each case. The units of the axes are meters.

- Rank the waves in order of increasing wavelength. Indicate equality whenever it occurs. Explain your answer.
- Rank the waves in order of increasing frequency. Indicate equality whenever it occurs. Explain your answer.

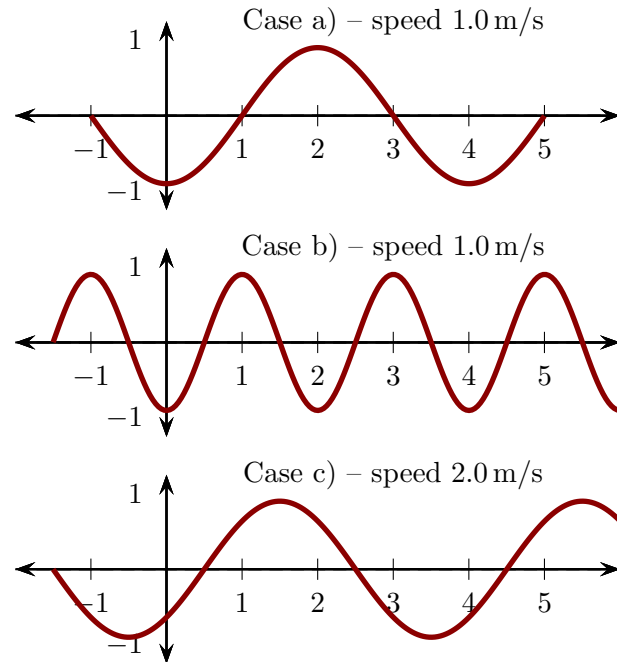

### 82 Waves on a string

A snapshot of a wave on a string is illustrated. The units of the axes are meters.

- Determine the wavelength of the wave.
- The wave is observed as time passes and it is found that 20 crests pass the 4 m mark in 5.0 s. Determine the wave speed.

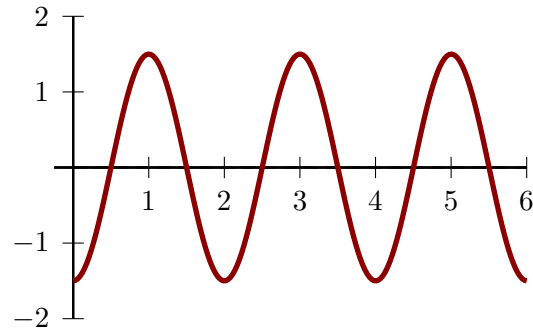

### 83 Waves on a string with an oscillating end

The PhET animation “Waves on a String” allows you to visualize transverse waves on a string. Find the animation at

<http://phet.colorado.edu/en/simulation/wave-on-a-string>

and open it. Adjust the settings as follows:

1. Check the button “No end” at the upper right.

2. Check the button “Oscillate” at the upper left.
  3. In the control panel at the bottom, adjust “Damping” to none.
  4. In the control panel at the bottom, adjust “Tension” to low.
  5. In the control panel at the bottom, check the “Rulers” and “Timer” buttons.
- a) Set the frequency to 0.30 Hz. Using the rulers and timer, determine the speed of the wave. Using the ruler, determine the wavelength of the wave. Determine the frequency of the wave by counting crests that pass a given point.
  - b) Set the frequency to 0.60 Hz. Repeat part a).
  - c) Is the speed the same in both cases?
  - d) Check that  $v = \lambda f$  in both cases.
  - e) For one of the frequencies, vary the amplitude and show that it does not affect the wave speed or wavelength.

#### 84 Sinusoidal waves

A snapshot of a segment of a wave on a string at a particular instant is illustrated. The distances are measured in meters.

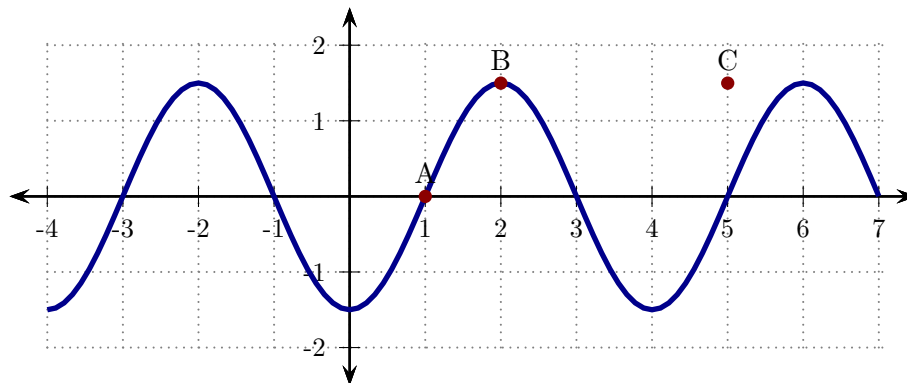

- a) The portion of the wave at A takes 0.0050 s to complete one cycle. Determine the frequency of the wave.
- b) Determine the wavelength and speed of the wave.
- c) Determine how long it will take the crest labeled B to reach the point C.
- d) Using the graph above, sketch the wave at an instant 0.0025 s after that illustrated above.

### 85 Interference of pulses

Two pulses on a string approach each other as illustrated; a snapshot at one instant is illustrated. The grid units are each 10 cm and the pulses travel with speed 10 cm/s.

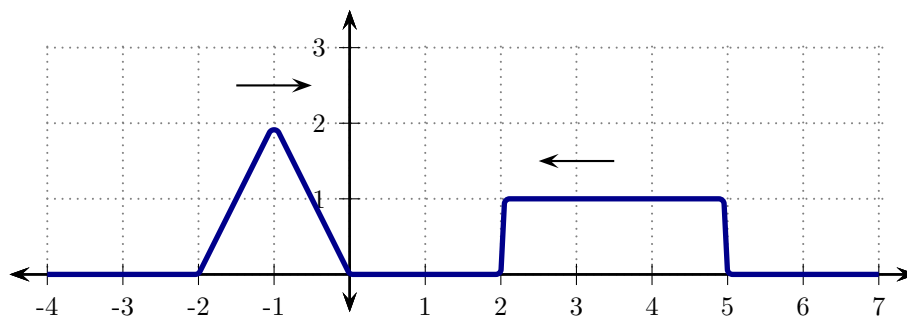

- Sketch the string at a moment 1.0 s after that illustrated in the figure.
- Sketch the string at a moment 2.0 s after that illustrated in the figure.
- Sketch the string at a moment 3.0 s after that illustrated in the figure.

### 86 Interference of pulses

Various pulses approach each other as illustrated. The pulses overlap and interfere; when each does so there will be a point of maximum displacement away from the horizontal.

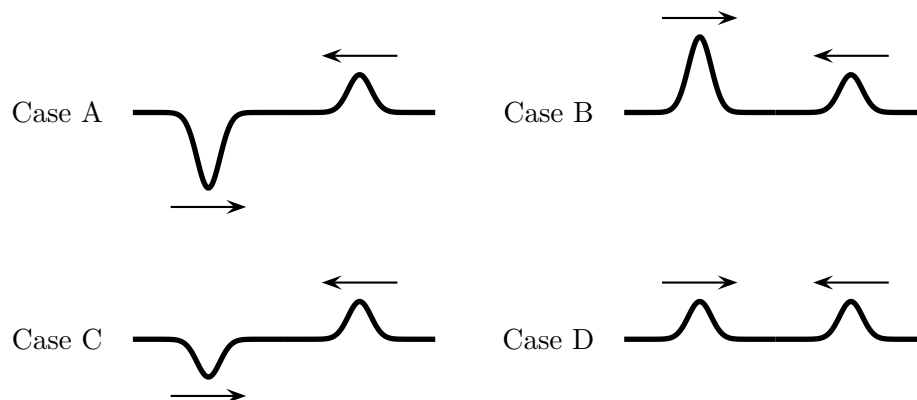

Rank the situations in order of increasing maximum displacement away from the horizontal during interference (indicate any ties in the ranking). Explain your answer.

## 87 Interference of waves

- a) Two sources produce waves that travel (along one direction) with speed 32 m/s. The sources oscillate with frequency 8.0 Hz. By what distances must the sources be separated to produce constructive interference? By what distances must the sources be separated to produce destructive interference?
- b) Two sources produce waves that travel in a medium with speed 300 m/s. It is found that the closest separation between the sources that results in destructive interference is 0.050 m. Determine the wavelength and frequency of the waves.



## Wave Optics

### 88 Double slit interference pattern: small angles

Light from a HeNe laser has wavelength  $632.8\text{ nm}$  and is incident on a pair of slits separated by  $40\ \mu\text{m} = 40000\text{ nm}$ . A pattern is produced on a screen a distance of  $1.25\text{ m}$  from the laser.

- a) Determine the angles at which the  $m = 1$ ,  $m = 2$  and  $m = 3$  bright fringes appear.
- b) Determine the distance from the central bright fringe to each of the first three fringes.
- c) Determine the separation between adjacent bright fringes.

### 89 Double slit interference

Light with wavelength  $\lambda$  is incident on a double slit with spacing  $d$ . A pattern is observed on a screen which is far from the slits (compared to the separation between the slits).

- a) Explain whether each of the following is correct or not.
- The pattern looks like a wave with bright fringes separated by a distance  $\lambda$ .
  - The pattern looks like a wave with bright fringes separated by a distance  $d$ .
  - The pattern looks like a wave with the locations of the bright fringes determined by the wavelength only.
  - The pattern looks like a wave with the locations of the bright fringes determined by the slit separation only.
- b) The wavelength is doubled to  $2\lambda$  and the slit spacing is also doubled to  $2d$ . Which of the following is true? Explain your answer.
- The separation between the fringes is a quarter of what it was before.
  - The separation between the fringes is a half of what it was before.
  - The separation between the fringes is the same as before.
  - The separation between the fringes doubles.
  - The separation between the fringes increases by four times.

### 90 Double slit interference patterns: different colors

Light with different colors is incident on a pair of double slits. The interference patterns are illustrated with the colored dots indicating bright fringes.

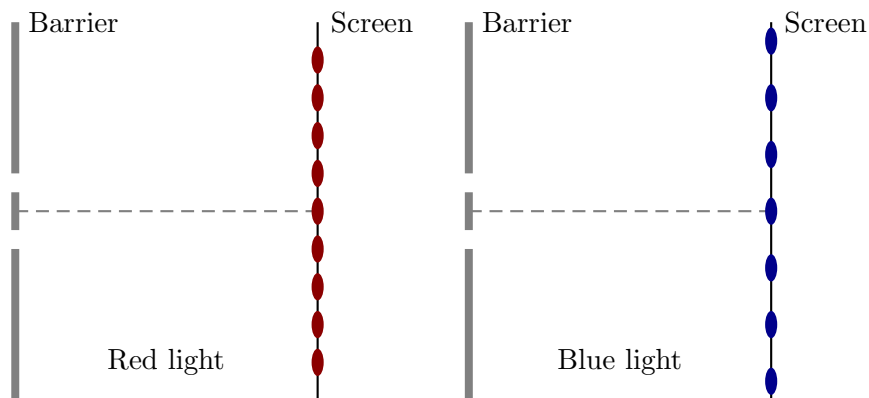

Based on the illustrated patterns how does the wavelength of the red light compare (same, larger, smaller, ...) to that of the blue light? Explain your answer, **using information from the patterns**.

### 91 Double slit interference patterns: determining wavelength

Light is incident on two slits whose separation is 0.500 mm. The distance from the slits to the screen is 1.75 m. The colored dots in the figure illustrate the centers of the bright fringes.

- Determine the wavelength of the light.
- Determine the distance from the central bright fringe to the  $m = 2$  bright fringe.
- The dotted lines indicate the paths taken by the waves from each slit to one particular bright fringe. Determine the difference in the length of these paths.

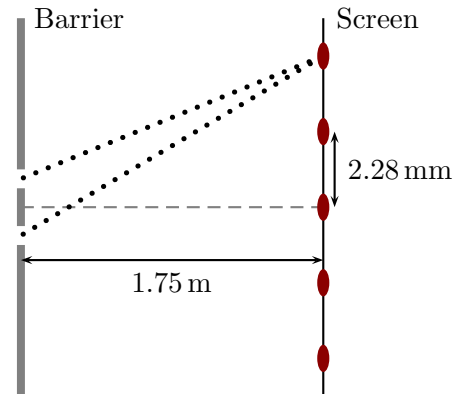

### 92 Double slit interference pattern

- Light with wavelength 650 nm illuminates a double slit where the spacing between the slits is 3500 nm. Determine the angles at which all the bright fringes appear.
- Light with wavelength  $\lambda$  illuminates a double slit with slit spacing  $8.1\lambda$ . Determine the number of bright fringes that appear.

### 93 Hydrogen emission spectrum

Light from hydrogen is passed through a diffraction grating. It is observed that the spectrum consists of three colors (red, turquoise, dark blue). It is observed that the first-order bright red fringe occurs at an angle of  $7.53^\circ$ ; the wavelength of this light is 656 nm. Then the first-order turquoise fringe is observed at  $5.54^\circ$  while the first-order dark blue fringe is observed at  $4.96^\circ$ .

- Determine the wavelengths of the turquoise and dark blue fringes.
- There is actually a fourth color that is too faint to be observed accurately but whose wavelength is 397 nm. Determine the angles at which the first-order fringe for this would occur.

#### 94 Single slit

Laser light is incident on a single slit whose width can be varied. The diffraction pattern is projected onto a distant screen. The slit width is initially  $a_0$  and is then narrowed to  $\frac{a_0}{5}$ . Which of the following is true regarding the width of the central maximum on the distant screen? Explain your answer.

- i) Width reduces to 1/5 of original width.
- ii) Width is halved.
- iii) Stays the same.
- iv) Width doubles.
- v) Width increases by a factor of 5.

#### 95 Single slit and white light

White light contains a mixture of light of all colors. Suppose that white light is incident on a single slit with width 0.25 mm.

- a) Determine the angle at which the first minimum in the diffraction pattern occurs for red light with wavelength 700 nm.
- b) Determine the angle at which the first minimum in the diffraction pattern occurs for violet light with wavelength 380 nm.
- c) Describe the appearance in terms of colors of the central bright spot in the diffraction pattern.

#### 96 Single slit diffraction

A single slit with width 0.020 mm is illuminated with light of various wavelengths. A pattern is produced on a screen 0.90 m from the slit.

- a) Determine the width of the central maximum if the wavelength of the light is 700 nm.
- b) Determine the width of the central maximum if the wavelength of the light is 400 nm.

### 97 Diffraction from two circular openings

Light with wavelength  $650\text{ nm}$  is incident on a barrier that contains two circular openings, each with diameter  $1.0\text{ mm}$ . The separation between the centers of the two openings is  $s$ .

- a) Sketch the two central diffraction maxima produced by the two apertures and use this to provide the minimum value of  $s$  in terms of the width of each maximum,  $w$ , such that the two maxima *do not overlap*.

- b) Determine the closest spacing between the holes so that they can be distinguished at a distance of  $5.0\text{ m}$ .

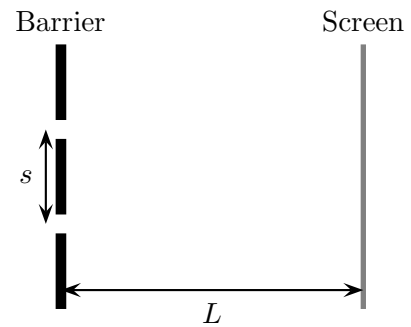

### 98 Optical resolution and wavelength

A piece of foil has two closely spaced, small circular holes. These are illuminated from behind – the light that passes through is used to form an image of the holes. Which of the following is true?

- One would be less likely to be able to distinguish the images of the holes by using red light rather than blue light.
- One would be less likely to be able to distinguish the images of the holes by using blue light rather than red light.
- One would be equally likely to be able to distinguish the images of the holes regardless of the color of the light used.

Explain your answer.

## Geometric Optics

### 99 Image formation by a flat mirror

An object labeled P is held in front of a flat mirror as illustrated. Small observers are located at the points labeled A, B, C and D. Indicate the location of the image of P produced by the mirror. Which observers will be able to see the image? Explain your answers.

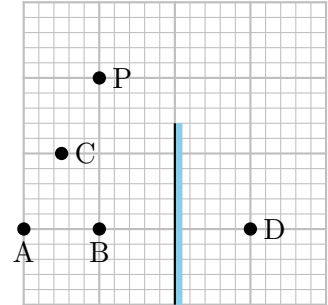

### 100 Visible image in a mirror

A stick labeled A is held parallel to a flat mirror as illustrated. Two small observers are located at the points labeled O and P. In the following, explain your answers.

- Suppose that the upper half of the mirror surface is covered by an opaque material. How much of the image of the stick will each observer be able to see?
- Suppose that the lower half of the mirror surface is covered by an opaque material. How much of the image of the stick will each observer be able to see?
- Suppose that the lower half of the mirror surface is covered by an opaque material and O moves away from the mirror (in a direction perpendicular to the mirror). As O moves away from the mirror does more or less of the image become visible?

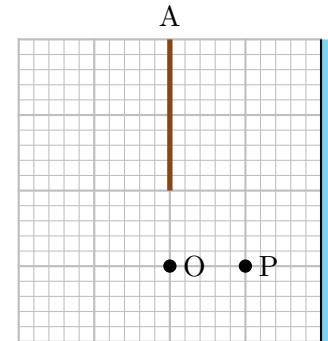

### 101 Image formation by parallel mirrors

Two mirrors are parallel as illustrated. The distance between them is 4.0 m. An object O is placed midway between the mirrors. Another object is placed at a quarter of the distance between the two mirrors.

- Determine the distance between successive images of O on either side.
- Are images of P on the right evenly spaced? Explain your answer.
- Are images of P on the left evenly spaced? Explain your answer.

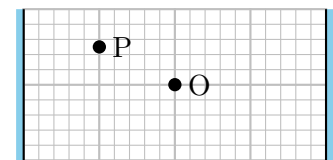

*If you can determine a formula for the locations of all the images for point P that will be impressive!*

### 102 Image formation by multiple mirrors

Two mirrors are oriented at right angles as illustrated. An object O is placed at the indicated point. Two observers, A and B are located as illustrated.

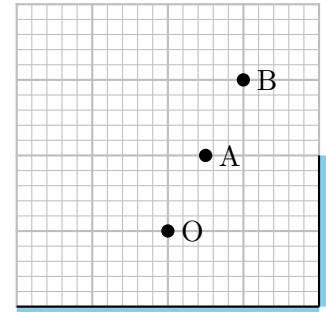

- Recreate the diagram accurately and indicate the locations of all the images of the object O. Explain your answer.
- Which of the images can observer A see? Explain your answer.
- Which of the images can observer B see? Explain your answer.

### 103 Index of refraction

A laser beam in air is incident on a transparent rectangular block as illustrated. The angles between the surfaces and the rays are as illustrated.

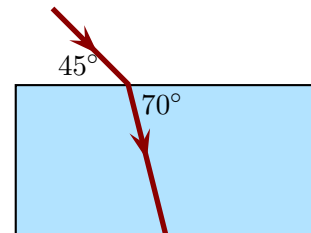

- Determine the index of refraction of the material from which the block is made.
- Determine the speed of light in the block.

### 104 Refraction through multiple materials

Two rectangular materials are stacked as illustrated. The indices of refraction of the materials and the surrounding medium are as illustrated. A light beam follows the indicated path. Which of the following is true regarding the indices of refraction? Explain your answer.

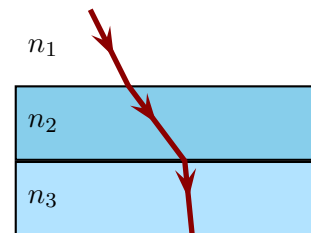

- $n_3 < n_1 < n_2$
- $n_1 < n_3 < n_2$
- $n_1 < n_2 < n_3$
- $n_3 < n_2 < n_1$
- $n_2 < n_1 < n_3$

### 105 Refraction through multiple materials

A rectangular slab of ice, with index of refraction 1.33 lies on top of a rectangular block of glass with index of refraction 1.55. Light traveling through the air is incident in the ice at an angle of  $50^\circ$  from the normal. Determine the angle at which the light travels through the glass.

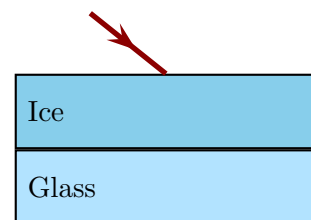

### 106 Refraction at multiple surfaces

A rectangular block of glass with index of refraction 1.55 is placed in air. The block has height 1.0 m and length 4.0 m. A light ray is incident midway along the length of the block at an angle  $\theta$  with respect to the surface.

- Determine where the light emerges back into the air and the direction in which it emerges the block if  $\theta = 70^\circ$ .
- Determine where the light emerges back into the air and the direction in which it emerges the block if  $\theta = 10^\circ$ .

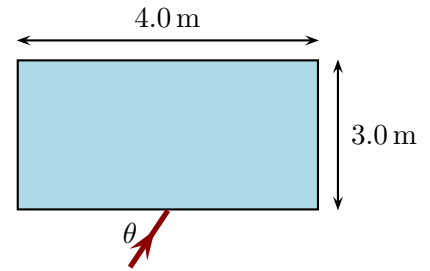



### 107 Image formation by a convex lens: object beyond focal point

A convex lens has focal length 2.0 cm. An arrow with height 2.0 cm is placed 6.0 cm left of the lens.

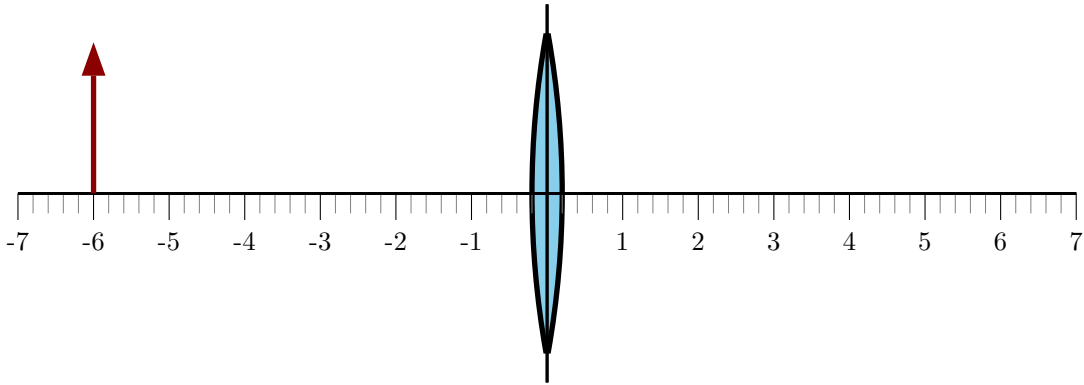

- Trace two rays from the tip of the arrow to determine where the image of the tip is produced.
- Determine the distance from the lens plane to the image of the arrow.
- Determine the height of the image of the arrow. Determine the magnification

$$m := \frac{h'}{h}$$

where  $h$  is the height of the object and  $h'$  is the height of the image.

The thin lens equation relates the positions of the object and the image via

$$\frac{1}{s} + \frac{1}{s'} = \frac{1}{f}$$

where  $s$  is the distance from the lens to the object and  $s'$  is the distance from the lens to the image.

- Use the thin lens equation to predict the location of the image. Check this against your diagram.
- The magnification equation predicts

$$m = -\frac{s'}{s}$$

Use this to predict the magnification and the height of the image. Check this against your diagram.

### 108 Image formation by a convex lens: object between lens and focal point

A convex lens has focal length 6.0 cm. An arrow with height 1.0 cm is placed 2.0 cm left of the lens.

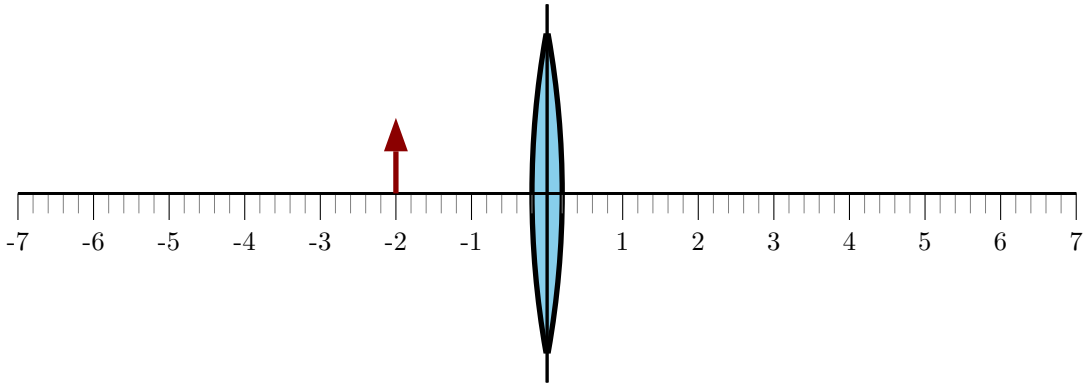

- Trace two rays from the tip of the arrow to determine where the image of the tip is produced.
- Determine the distance from the lens plane to the image of the arrow.
- Determine the height of the image of the arrow. Determine the magnification

$$m := \frac{h'}{h}$$

where  $h$  is the height of the object and  $h'$  is the height of the image.

The thin lens equation relates the positions of the object and the image via

$$\frac{1}{s} + \frac{1}{s'} = \frac{1}{f}$$

where  $s$  is the distance from the lens to the object and  $s'$  is the distance from the lens to the image.

- Use the thin lens equation to predict the location of the image. Check this against your diagram.
- The magnification equation predicts

$$m = -\frac{s'}{s}$$

Use this to predict the magnification and the height of the image. Check this against your diagram.

### 109 Image formation by a concave lens

A concave lens has focal length  $-3.0$  cm. An arrow with height  $2.0$  cm is placed  $5.0$  cm left of the lens.

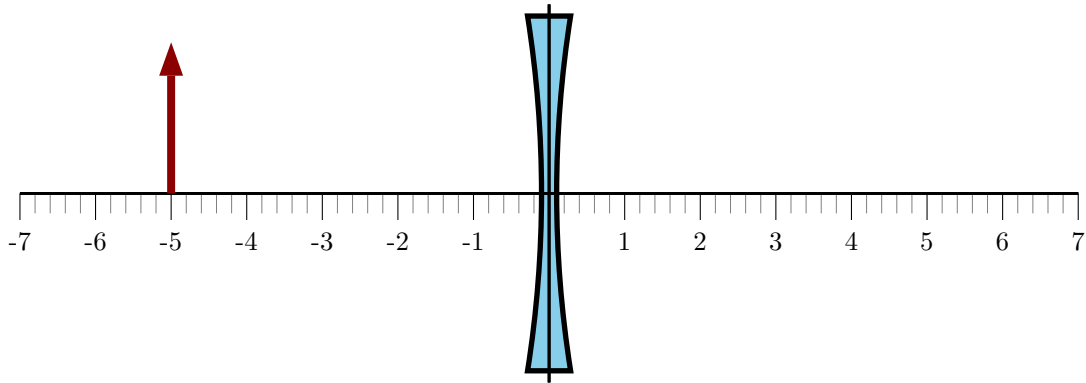

- Trace two rays from the tip of the arrow to determine where the image of the tip is produced.
- Determine the distance from the lens plane to the image of the arrow.
- Determine the height of the image of the arrow. Determine the magnification

$$m := \frac{h'}{h}$$

where  $h$  is the height of the object and  $h'$  is the height of the image.

The thin lens equation relates the positions of the object and the image via

$$\frac{1}{s} + \frac{1}{s'} = \frac{1}{f}$$

where  $s$  is the distance from the lens to the object and  $s'$  is the distance from the lens to the image.

- Use the thin lens equation to predict the location of the image. Check this against your diagram.
- The magnification equation predicts

$$m = -\frac{s'}{s}$$

Use this to predict the magnification and the height of the image. Check this against your diagram.

### 110 Images formed by a convex lens

An object is placed to the left of a convex lens. The object is between the lens and the focal point.

- a) The object is moved closer to the lens. Which of the following is true? Explain your choice.
  - i) The image stays in the same place as the object is moved.
  - ii) The image moves towards the lens as the object is moved.
  - iii) The image moves away from the lens as the object is moved.
  - iv) The image is always at the focal point.
- b) The object is moved closer to the lens. Which of the following is true? Explain your choice.
  - i) The image height increases as the object is moved.
  - ii) The image height decreases as the object is moved.
  - iii) The image stays constant as the object is moved.
- c) Explain whether it is possible for the image to be located between the object and the lens.
- d) Explain whether it is possible for the image to be larger than the object (while the object is between the lens and the focal point).

### 111 Images formed by a concave lens

An object is placed to the left of a concave lens.

- a) The object is moved closer to the lens. Which of the following is true? Explain your choice.
  - i) The image stays in the same place as the object is moved.
  - ii) The image moves towards the lens as the object is moved.
  - iii) The image moves away from the lens as the object is moved.
  - iv) The image is always at the focal point.
- b) The object is moved closer to the lens. Which of the following is true? Explain your choice.
  - i) The image height increases as the object is moved.
  - ii) The image height decreases as the object is moved.
  - iii) The image stays constant as the object is moved.
- c) Explain whether it is possible for the image to be located left of the object.
- d) Explain whether it is possible for the image to be larger than the object (while the object is between the lens and the focal point).

**112 Image formation by a convex lens**

An object with height 2.0 cm is placed 5.0 cm to the left of a convex lens with focal length 3.0 cm.

- a) Determine the location and height of the image using an accurate ray-tracing diagram.
- b) Determine the exact location and height of the image by using equations.

**113 Image formation by a convex lens**

An object with height 2.0 cm is placed 1.0 cm to the left of a convex lens with focal length 3.0 cm.

- a) Determine the location and height of the image using an accurate ray-tracing diagram.
- b) Determine the exact location and height of the image by using equations.

**114 Image formation by a concave lens**

An object with height 2.0 cm is placed 6.0 cm to the left of a concave lens with focal length  $-8.0$  cm.

- a) Determine the location and height of the image using an accurate ray-tracing diagram.
- b) Determine the exact location and height of the image by using equations.

**115 Magnified images produced by convex lenses**

- a) An object is placed left of a convex lens with focal length  $f$ . Determine, in terms of  $f$ , where the object must be placed in order to produce an image with magnification  $-1$ .
- b) An object is placed left of a concave lens with focal length  $f$ . Determine, in terms of  $f$ , where the object must be placed in order to produce an image with magnification  $\frac{1}{2}$ .

**116 Projector**

A projector uses a convex lens with focal length 15 cm to form an image of an object, that is inside the projector behind the lens, on a distant screen. The distance between the object and image is fixed at 2.2 m. The lens can be shifted back and forth to produce a clear image.

- a) Determine the distance between the object and lens so that a clear image is produced on the screen.
- b) Determine the magnification of the image.

### 117 Lens in water

A lens is constructed using glass for which the index of refraction is 1.50 and when placed in air it has a focal length of 48 mm. Suppose that the lens is placed in water. Does the focal length remain the same or change? If it changes, describe whether it is larger than or smaller than 48 mm. Explain your answer.

### 118 Projector

A projector uses a convex lens to form an image of an object that is 4.0 cm tall. The image is 1.2 m tall. The distance from the lens to the screen is 3.0 m. Determine the focal length of the lens needed to do this.

### 119 Concave lens: image formation

A concave lens is used to form an image of an upright object.

- a) The following refer to the focal point that is on the same side of the lens as the object. Which of the following is true? Explain your choice.
- i) The image will be upright regardless of where the object is located.
  - ii) The image will be inverted regardless of where the object is located.
  - iii) The image will be upright when the object is beyond the focal point of the lens and inverted when the object is between the focal point and the lens.
  - iv) The image will be inverted when the object is beyond the focal point of the lens and upright when the object is between the focal point and the lens.
- b) The following refer to the focal point that is on the same side of the lens as the object. Which of the following is true? Explain your choice.
- i) The image will be between the focal point and the lens regardless of where the object is located.
  - ii) The image will be beyond the focal point regardless of where the object is located.
  - iii) The image could be either side of the focal point depending on where the object is located.

### 120 Nearsightedness

A nearsighted person has a far point of 1.5 m and a normal near point of 0.25 m. A single corrective lens is used to allow that person to view objects that are infinitely distant. Assume that the lens is placed against the eye.

- a) Determine the focal length of the lens so that the person can view an object that is infinitely distant. Is the image of this object (created by the corrective lens) larger or smaller than the object?
- b) Determine the location of the closest object that the person can see clearly.
- c) With this corrective lens, what is the range of vision of the person?

### 121 Farsightedness

A farsighted person has a far point of 0.35 m and a far point at infinity. A single corrective lens is used to allow that person to view objects that are at the normal near point, 0.25 m. Assume that the lens is placed against the eye.

- a) Determine the focal length of the lens so that the person can view an object that is at the normal near point. Is the image of this object (created by the corrective lens) larger or smaller than the object?
- b) Determine the location of the furthest object that the person can see clearly.
- c) With this corrective lens, what is the range of vision of the person?



### 122 Magnifier

A magnifier produces an angular magnification of 10 for a person with a normal near point.

- a) Determine the focal length of the lens.
- b) Determine the angular magnification for someone with a near point of 0.40 m.

## Photons/Light Matter Interactions

### 123 Photon emission rates

Consider the following two light sources. Light A emits light with wavelength 400 nm and power 15 W. Light B emits light with wavelength 600 nm and power 10 W. Which of the following is true?

- i) The number of photons emitted per second by A is the same as that emitted per second by B.
- ii) The number of photons emitted per second by A is larger than that emitted per second by B.
- iii) The number of photons emitted per second by A is smaller than that emitted per second by B.

**Explain your answer.**

### 124 Mercury spectrum wavelengths

Mercury emits visible light at the following wavelengths: 404.7 nm, 435.8 nm, 546.1 nm (there are several other dimmer visible spectral lines). Determine the energy of a photon of the light of each of these spectral lines in units of electron Volts (an electron Volt (eV) is a unit of energy and  $1 \text{ eV} = 1.6 \times 10^{-19} \text{ J}$ ).

### 125 Laser power

A HeNe laser produces light with wavelength 632.8 nm.

- a) Suppose that the laser produces  $1.6 \times 10^{19}$  photons per second. Determine the power provided by the laser.
- b) The laser light passes through an optical attenuator that reduces its intensity. The intensity of the light that passes through the attenuator is 0.0010 times the intensity of the light that arrives at the attenuator. Determine the number of photons that pass through the attenuator every second.

### 126 Double slit interference: photons

Photons are fired, one at a time toward a barrier that contains two slits. The diagram illustrates that probability with which they arrive at various locations on a screen. The arrows indicate two locations, A and B, on the screen.

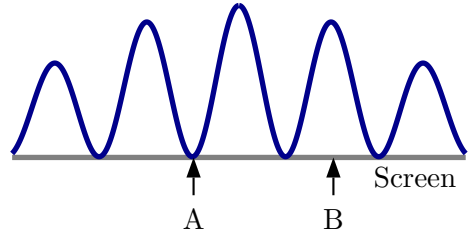

- a) A photon is fired toward the screen and it hits location B. The next photon is then fired toward the screen. Which of the following is true about the next photon to arrive on the screen? Explain your answer.
- i) The photon will definitely not arrive at A and will definitely not arrive at B.
  - ii) The photon will definitely not arrive at A and will definitely arrive at B.
  - iii) The photon will definitely not arrive at A and might arrive at B.
  - iv) The photon will definitely not arrive at B and will definitely arrive at A.
  - v) The photon will definitely not arrive at B and might arrive at A.
- b) Which of the following modifications (select all that could be correct) could cause the next photon to arrive at A? Explain your answer.
- i) Increasing the intensity of light.
  - ii) Decreasing the intensity of light.
  - iii) Increasing the wavelength of light.
  - iv) Decreasing the wavelength of light.
  - v) Increasing the slit separation.
  - vi) Decreasing the slit separation.

### 127 Double slit interference: photons

Light with one wavelength is incident on a double slit barrier. The diagram illustrates the intensity of the light at various locations on a screen. The arrows indicate two locations, A and B, on the screen.

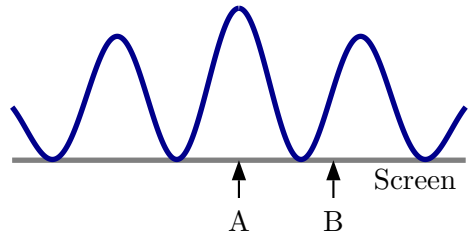

- a) Consider the statement: "A photon that arrives at A has more energy than a photon that arrives at B." Is this statement true or false? Explain your answer.
- b) Suppose that in a short period of time 8000 photons arrive at A. Approximately how many will arrive at B during the same period of time?

## Particles and Waves

### 128 Double slit interference: particles

In various experiments particles are fired toward a barrier that contains two slits. The diagrams illustrate the probabilities with which they arrive at various locations.

- Suppose that, in separate experiments, electrons and protons are fired toward one particular barrier. Which of the two diagrams (case A or B) would be the distribution for the electron experiment and which would be the diagram for the proton experiment? Explain your answer.
- Suppose that in two experiments, neutrons are fired toward the barrier. In one experiment they are all fired at a higher speed, in the other all at a lower speed. Which of the two diagrams (case A or B) would be the distribution for the higher speed experiment and which would be the diagram for the lower speed experiment? Explain your answer.

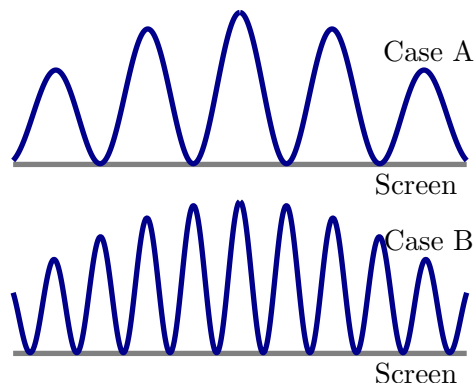

### 129 Particle diffraction

Particle diffraction experiments have been done with various particles. The particles produce a pattern on a screen; the pattern is centered about the direction in which the particles approached the diffraction grating. A beam of carbon-60 molecules (each contains 60 carbon molecules) is sent through a diffraction grating; the spacing between adjacent slits is 100 nm. The mass of each molecule is  $1.20 \times 10^{-24}$  kg and the speeds with which they approached the grating is 220 m/s. Determine the angles at which the first order bright spots on the screen appear. *The angles are small but can be detected.*

## Matter and Light

### 130 Sodium atom

A sodium atom has many energy levels. Several of these effectively have energies:

$$0.000 \text{ eV}, 2.104 \text{ eV}, 3.191 \text{ eV}, \text{ and } 3.617 \text{ eV}.$$

Determine all possible wavelengths of light that are emitted by the sodium atom (*aside: it turns out that one of these is actually extremely unlikely - ignore this fact for the moment.*)